

TITE-LOC

PRODUCT FEATURES

- 20 year non-prorated finish warranty
- Herr-Voss corrective leveled
- Available with striations or striations with pencil ribs
- Maximum panel length of 64 feet
- Mechanically seamed in the field to 90 degree lock

MATERIAL

- 37 stocked colors (24 gauge steel)
- 13 stocked colors (22 gauge steel)
- 36 stocked colors (.032 aluminum)
- 18 stocked colors (.040 aluminum)
- Smooth and stucco embossed available (not available in .040 Tite-Loc)
- Galvalume Plus available

*24 ga. and 22 ga. steel panels are UL-90 classified over solid substrate. See roof deck construction in Underwriter Laboratories roofing materials and systems directory.

UL CLASSIFICATION

- UL-580 Class 90 rated up to 18" O.C.
- UL-1897 wind uplift
- UL-790 Class A fire rated
- UL-263 fire resistance rated
- UL-2218 impact resistance rated

ASTM TESTS

- ASTM E1592 tested
- ASTM E331 tested
- ASTM E283 tested

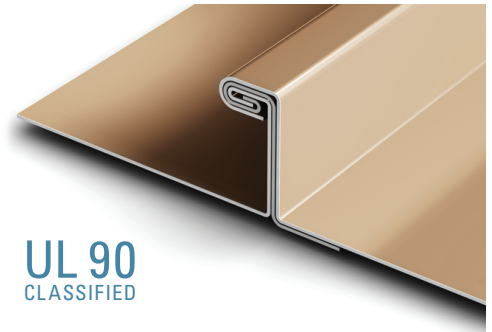

UL 90
CLASSIFIED

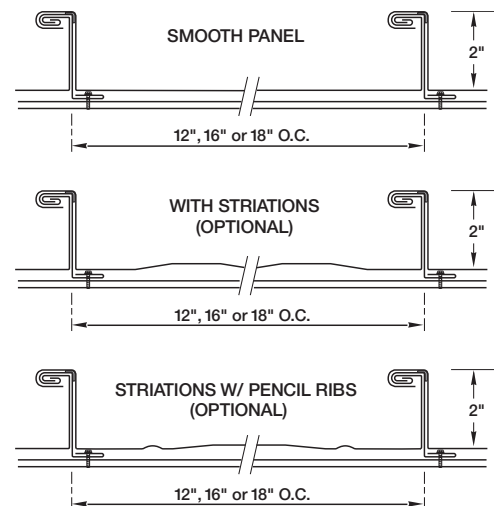

SPECS: 12", 16" OR 18" O.C.
2" HIGH



www.pac-clad.com | 800-PAC-CLAD

©2008-2009 Petersen Aluminum Corporation