

TITE-LOC HS

PRODUCT FEATURES

- 20 year non-prorated finish warranty
- Herr-Voss corrective leveled
- Available with striations or striations with pencil ribs
- Maximum panel length of 64 feet

MATERIAL

- 37 stocked colors (24 gauge steel)
- 13 stocked colors (22 gauge steel)
- 36 stocked colors (.032 aluminum)
- 18 stocked colors (.040 aluminum)
- Smooth and stucco embossed available (not available in .040 Tite-Loc HS)
- Galvalume Plus available

*24 ga. and 22 ga. steel panels are UL-90 classified over solid substrate.
See roof deck construction in Underwriter Laboratories roofing materials and systems directory.

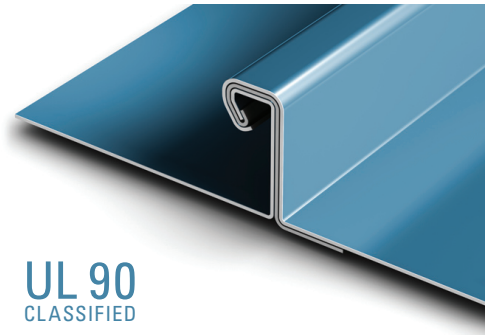

UL 90
CLASSIFIED

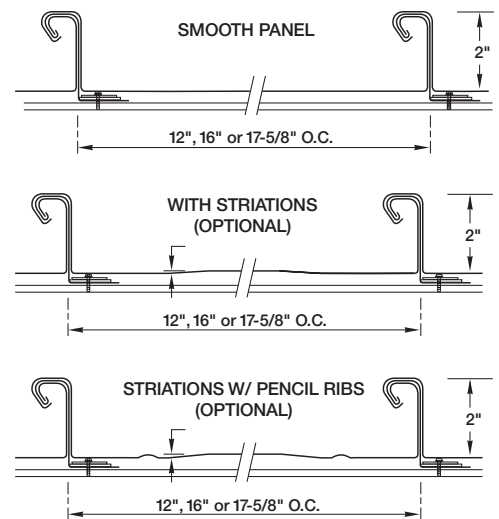

SPECS: 12", 16" OR 17-5/8" O.C.
2" HIGH



www.pac-clad.com | 800-PAC-CLAD

©2008-2009 Petersen Aluminum Corporation