

TITE-LOC PLUS

PRODUCT FEATURES

- 20 year non-prorated finish warranty
- Herr-Voss corrective leveled
- Available with striations or striations with pencil ribs
- Maximum panel length of 64 feet
- Mechanically seamed in the field to 180 degrees

MATERIALS

- 37 stocked colors (24 gauge steel)
- 13 stocked colors (22 gauge steel)
- 36 stocked colors (.032 aluminum)
- 18 stocked colors (.040 aluminum)
- Smooth and stucco embossed available (not available in .040 Tite-Loc Plus)
- Galvalume Plus available

UL CLASSIFICATION

- UL-580 Class 90 rated up to 18" O.C.
- UL-1897 wind uplift
- UL-790 Class A fire rated
- UL-263 fire resistance rated
- UL-2218 impact resistance rated

ASTM TESTS

- ASTM E1592
- ASTM E331/1646
- ASTM E283/1680

FLORIDA BUILDING PRODUCT APPROVALS

- Open Purlins: FL Prod. Approv. #5562
- .040 Aluminum: FL Prod. Approv. #10879
- 22 ga. Deck & Plywood: FL Prod. Approv. # FL 13487
- FL DOE Hurricane Testing

MIAMI-DADE PRODUCT APPROVALS

- .032 Aluminum: NOA No.: 07-0924.09
- 24 ga. Steel: NOA No.: 07-0924.10

TESTS

- 24 ga. Steel SSTD Missile Impact Tested - Passed
- .032 Aluminum SSTD Missile Impact Tested - Passed

*24 ga. and 22 ga. steel panels are UL-90 classified over solid substrate. See roof deck construction in Underwriter Laboratories roofing materials and systems directory.

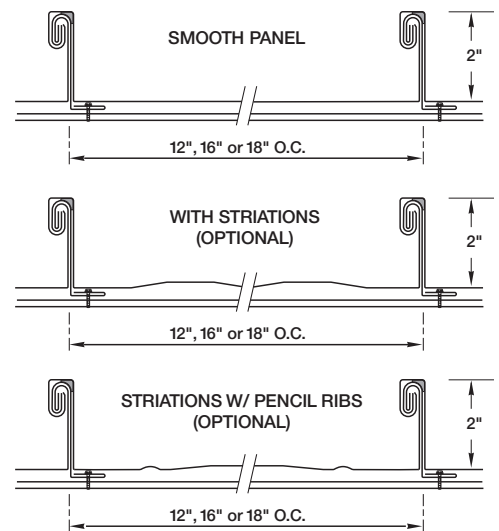
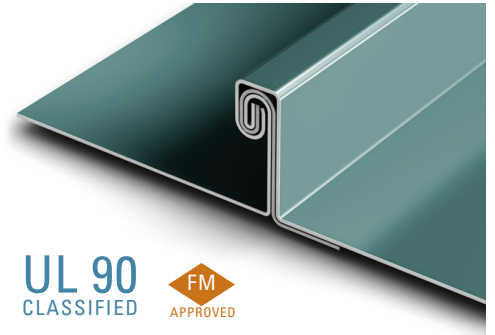

SPECS: 12", 16" OR 18" O.C.
2" HIGH

