

# PAC-150 90° SEAM

## MATERIALS

.032 aluminum	24 gauge steel
.040 aluminum	22 gauge steel

## SPECS

12", 16", 18"  
or 20" O.C.                      1-1/2" High

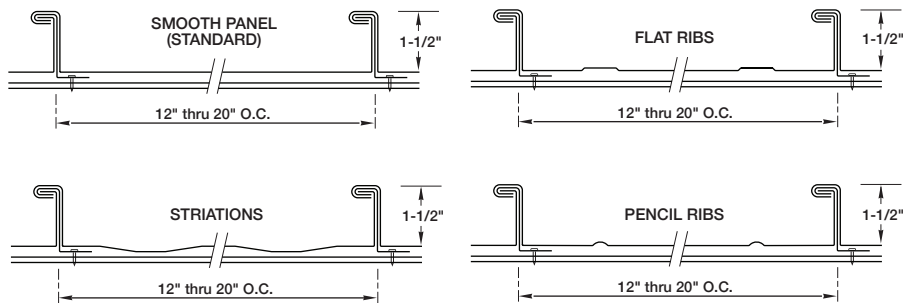
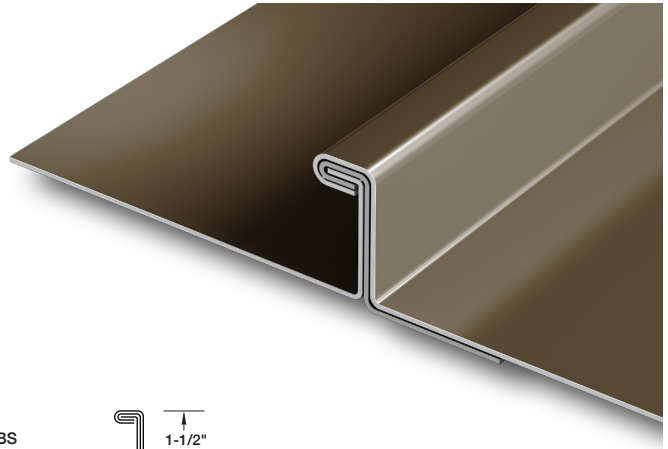

## PRODUCT FEATURES

- ▶ 30-year non-prorated finish warranty
- ▶ Available in four pan variations; smooth, striated, pencil rib or flat rib. Check locally for panel condition availability
- ▶ Corrective-leveled coil
- ▶ Maximum panel length of 64' when factory or shop-formed but virtually unlimited when field-formed

- ▶ Mechanically seamed in the field to 90°

## MATERIAL

- ▶ 43 stocked colors (24 gauge steel)
- ▶ 15 stocked colors (22 gauge steel)
- ▶ 36 stocked colors (.032 aluminum)
- ▶ 22 stocked colors (.040 aluminum)
- ▶ Galvalume Plus available

## UL CLASSIFICATION

- ▶ UL-580
- ▶ UL-1897
- ▶ TAS-125

## FLORIDA BUILDING PRODUCT APPROVALS

Contact the Acworth, Georgia facility for PAC-150 product approvals.