

PAC SS RIDGE VENT

SLOPED ROOF MEETS VERTICAL WALL, SHINGLED VERSION

INSTALLATION INSTRUCTIONS

U.S. PATENT # 7,823,343 B1

DETAIL A

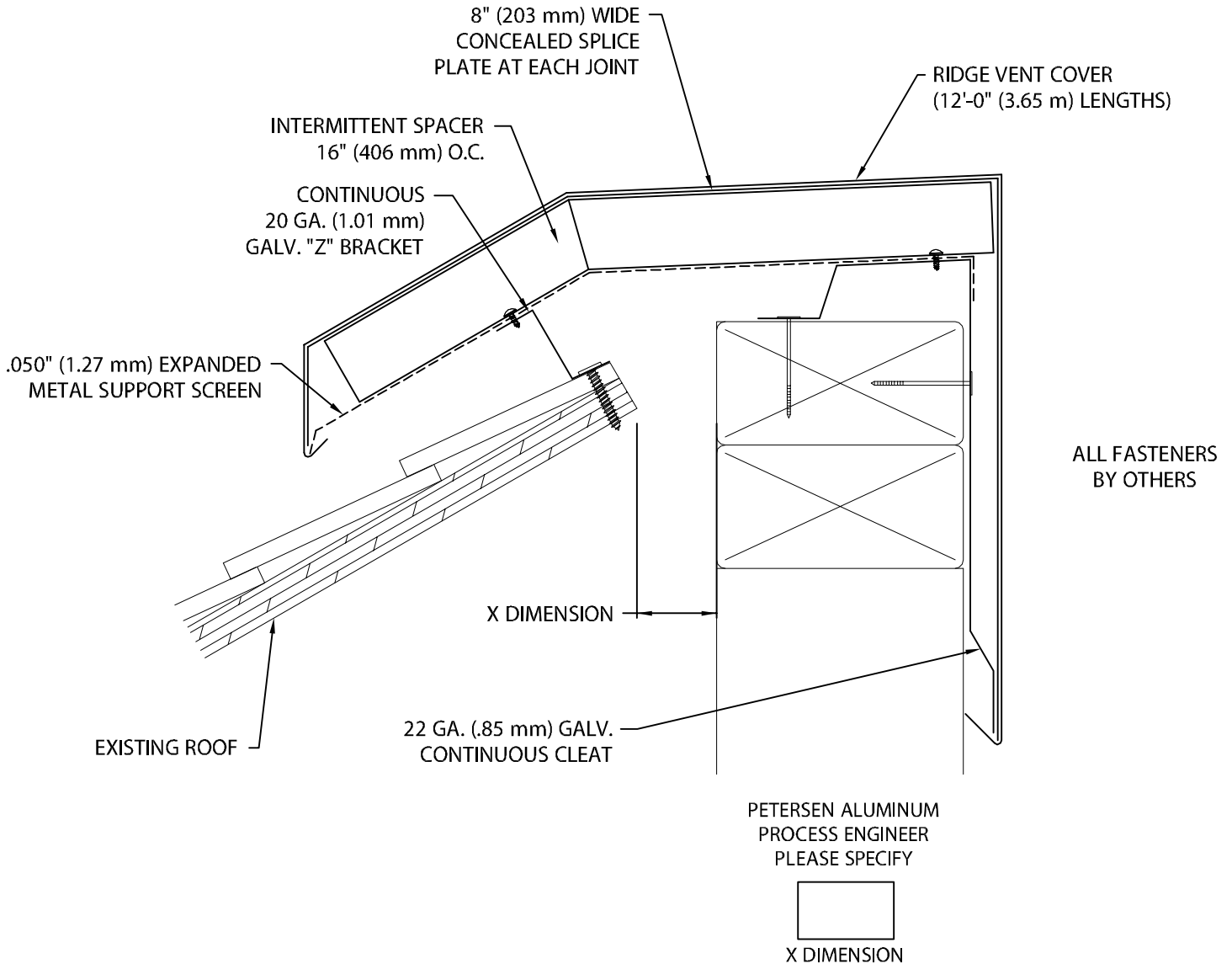

CAUTION! INSTALLERS SHALL WEAR PROTECTIVE EYE WEAR TO PREVENT INJURY. DO NOT OVERDRIVE FASTENERS, AS STRIPPING CAN OCCUR AT HIGH DRIVER TORQUE. RECOMMENDED DRIVING TOOL: 600 - 800 rpm ELECTRIC DRILL EQUIPPED WITH DEPTH-SENSING NOSE-PIECE TO PREVENT DRIVING AND STRIPOUT. DO NOT USE IMPACT TYPE TOOL.

IMPORTANT! BE SURE TO REMOVE PROTECTIVE PLASTIC FILM PRIOR TO INSTALLING EACH COVER SECTION.

NOTE: ALL FASTENERS MUST MEET MINIMUM 240 LB. PULL-OUT FOR SUBSTRATE.



Phone: 800-323-1960
 Fax: 800-722-7150
 www.pac-clad.com
 E-mail: info@pac-clad.com

DATE: 05/23/12	SHT.# 1 OF 4
DRN BY: JJC	DWG# 41124-15321
CKD BY: SAK	

PAC SS RIDGE VENT

SLOPED ROOF MEETS VERTICAL WALL, SHINGLED VERSION

INSTALLATION INSTRUCTIONS

U.S. PATENT # 7,823,343 B1

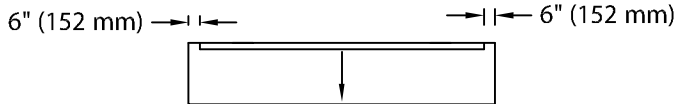
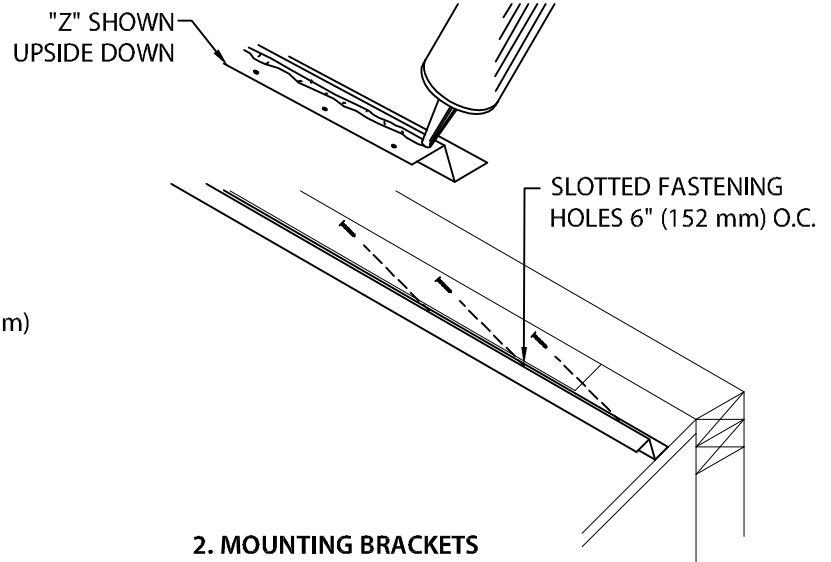

1. PREPARE RIDGE

CUT OPENING AT RIDGE "X" DIMENSION. (SEE DETAIL "A".)

2. MOUNTING BRACKETS

TO PREVENT MOISTURE ENTRY UNDER THE "Z", APPLY A GENEROUS BEAD OF NON-CURING SEALANT TO BOTTOM OF FLANGE. FASTEN BRACKETS AT ROOF AT 6" (152 mm) O.C. WITH APPROPRIATE FASTENERS USING PRE-PUNCHED SLOTTED HOLES. LAP "Z'S" 1" (25 mm).

NOTE: FOAM/SEALANT SHOULD BE PLACED BETWEEN THE "Z" AND VERTICAL WALL OVER THE OSB ON THE LAST 6" (152 mm) AT BOTH ENDS (SEE STEP 1)

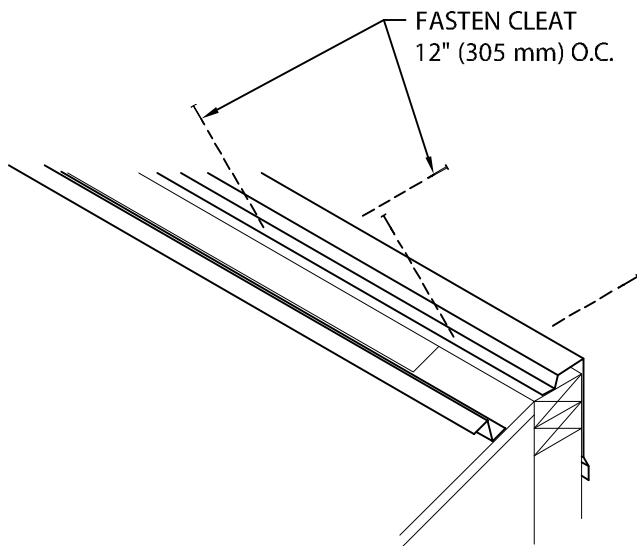

3. CONTINUOUS CLEAT

FASTEN CONTINUOUS CLEAT TO WALL IN FACE AND TOP FLANGE 12" (305 mm) O.C. AS SHOWN USING APPROPRIATE FASTENERS FOR SUBSTRATE.

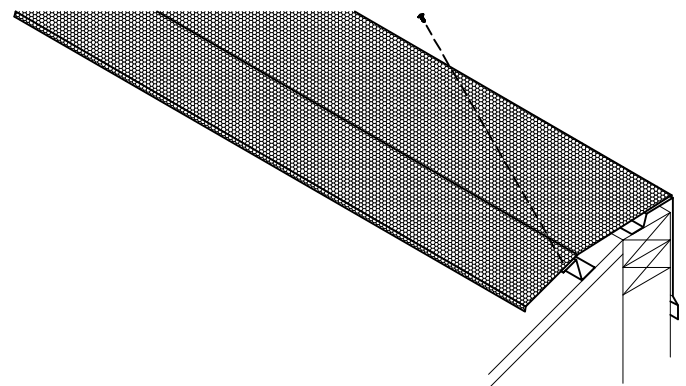

4. EXPANDED METAL SUPPORT SCREEN

PLACE SCREEN CENTERED OVER "Z" BRACKETS. TEMPORARILY FASTEN TO "Z" BRACKETS AT EACH END OF 12'-0" (3.65 m) LENGTH TO HOLD IN PLACE.



Phone: 800-323-1960
Fax: 800-722-7150
www.pac-clad.com
E-mail: info@pac-clad.com

DATE: 05/23/12

SHT.# 2 OF 4

DRN BY: JJC

CKD BY: SAK

DWG# 41124-15321

B

PAC SS RIDGE VENT

SLOPED ROOF MEETS VERTICAL WALL, SHINGLED VERSION

INSTALLATION INSTRUCTIONS

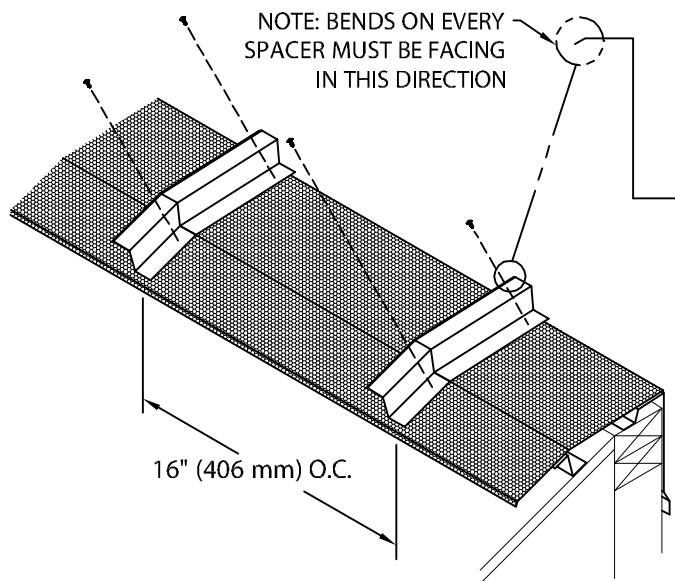

5. INTERMITTENT SPACERS

STARTING AT THE END OF THE ROOF WHERE THE ENDCAPS WILL BE PLACED, FASTEN INTERMITTENT SPACERS THRU SCREEN INTO "Z" BRACKET AND CONTINUOUS CLEAT 16" (406 mm) O.C. AS SHOWN WITH APPROPRIATE FASTENERS. THE BENDS ON TOP OF THE SPACER MUST ALL BE FACING AWAY FROM THE END OF THE ROOF.

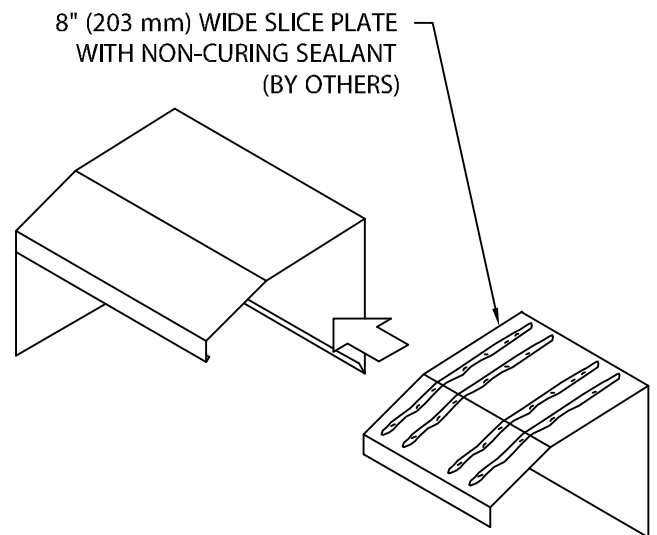

6. ENDCAP SPLICE PLATE

APPLY NON-CURING SEALANT (BY OTHERS) TO TOP OF 8" (203 mm) WIDE SPLICE PLATE AS SHOWN. INSTALL THE SPLICE PLATE INTO ENDCAP SO THAT HALF THE SPLICE PLATE IS EXPOSED.

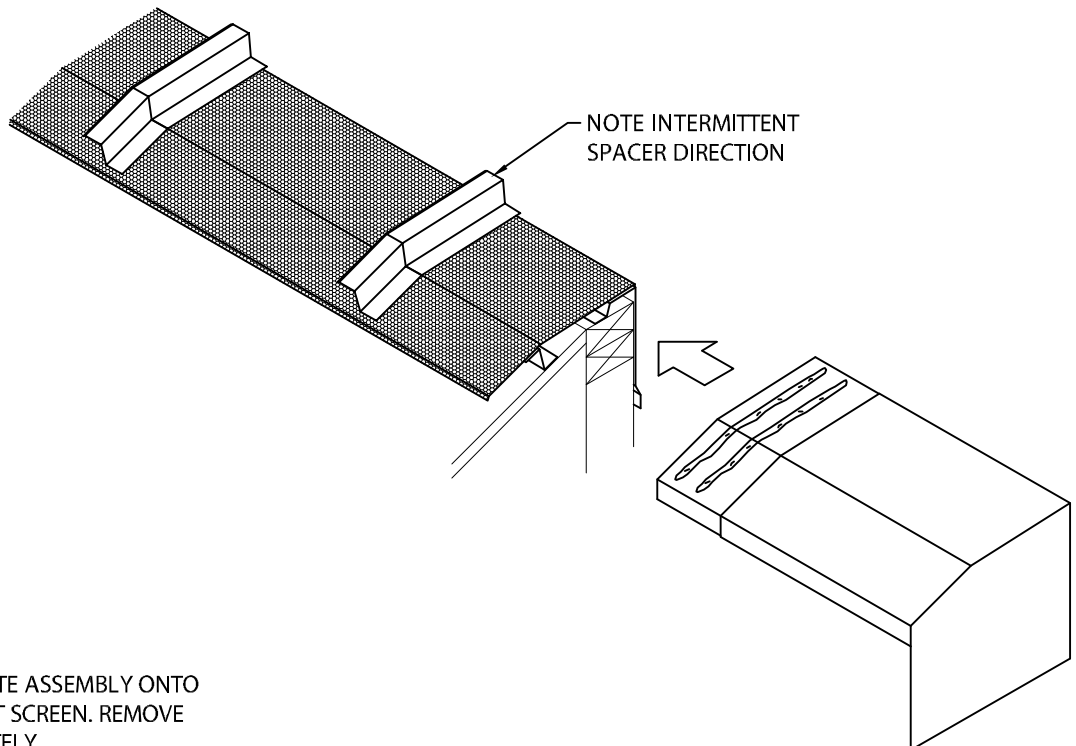

7. ENDCAPS

SLIDE ENDCAP / SPLICE PLATE ASSEMBLY ONTO EXPANDED METAL SUPPORT SCREEN. REMOVE PROTECTIVE FILM IMMEDIATELY.



Phone: 800-323-1960
Fax: 800-722-7150
www.pac-clad.com
E-mail: info@pac-clad.com

DATE: 05/23/12

SHT.# 3 OF 4

DRN BY: JJC

CKD BY: SAK

DWG# 41124-15321

B

PAC SS RIDGE VENT

SLOPED ROOF MEETS VERTICAL WALL, SHINGLED VERSION

INSTALLATION INSTRUCTIONS

U.S. PATENT # 7,823,343 B1

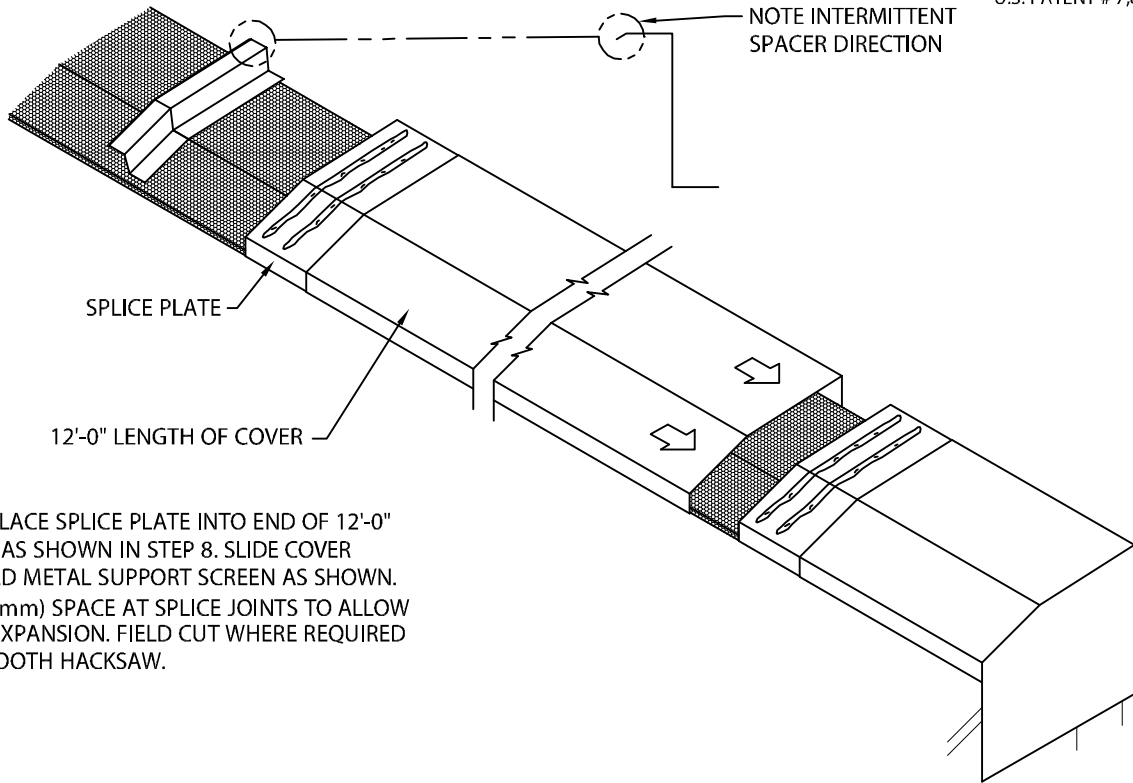

8. COVER

PREPARE AND PLACE SPLICE PLATE INTO END OF 12'-0" (3.65 m) COVER AS SHOWN IN STEP 8. SLIDE COVER ONTO EXPANDED METAL SUPPORT SCREEN AS SHOWN. LEAVE A $\frac{3}{8}$ " (10 mm) SPACE AT SPLICE JOINTS TO ALLOW FOR THERMAL EXPANSION. FIELD CUT WHERE REQUIRED USING A FINE TOOTH HACKSAW.

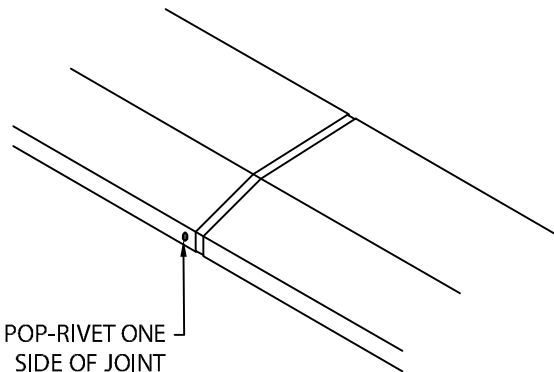

9. POP-RIVET

POP-RIVET SPLICE TO ONE SIDE JOINT TO PREVENT JOINT MIGRATION. CONTINUE INSTALLING COVER WITH A $\frac{3}{8}$ " (10 mm) SPACE AT SPLICE PLATES TO ALLOW FOR THERMAL EXPANSION FIELD CUT WHERE REQUIRED USING A FINE TOOTH HACKSAW.

NOTE: REMOVE PROTECTIVE FILM IMMEDIATELY.



PAC-CLAD
PETERSEN

Phone: 800-323-1960
Fax: 800-722-7150
www.pac-clad.com
E-mail: info@pac-clad.com

DATE: 05/23/12

DRN BY: JJC

CKD BY: SAK

SHT.# 4 OF 4

DWG# 41124-15321

B