

PAC-TITE GOLD COPING

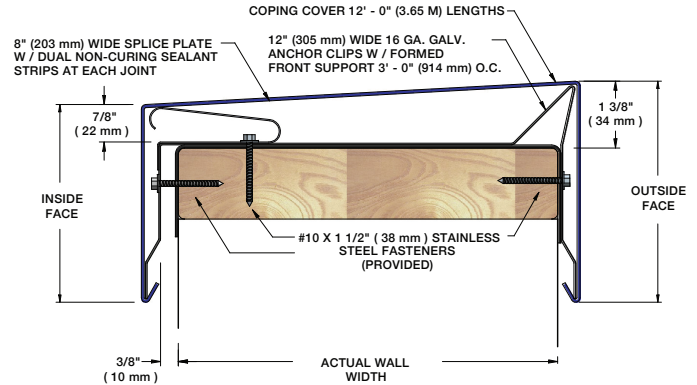

PRODUCT FEATURES

- ▶ Elimination of field-crimping for certain products
- ▶ Wide variety of colors and finishes
- ▶ Compliant with most relevant building codes
- ▶ Superior, efficient design for ease of installation
- ▶ Custom fabricated to the specific job requirements to ensure superior fit
- ▶ Extensively tested for reliable, long-term performance
- ▶ Convenient 12' lengths
- ▶ Reusable and recyclable material
- ▶ Custom and radius capabilities available

MATERIALS

- ▶ 43 Stocked PAC-CLAD finishes (24 gauge steel)
- ▶ 22 Stocked PAC-CLAD finishes (.040 aluminum)
- ▶ 29 Stocked PAC-CLAD Finishes (.050 aluminum)
- ▶ 6 Stocked PAC-CLAD Finishes (.063 aluminum)
- ▶ Mill Finish Aluminum (.050 & .063 aluminum)
- ▶ Clear and Colored Anodized (.050 & .063 aluminum)

TESTING

- ▶ ANSI/SPRI/FM 4435/ES-1 Standard to comply with the International Building Code
- ▶ Factory Mutual approved for wind uplift protection

WARRANTY

A Lifetime 215 mph warranty is available. It covers replacement or repair of any portion of the roof edge system that has failed due to a defect in the supplied materials. The warranty covers the roof edge for the lifetime of the roof on which it was originally installed.