

PAC-TITE COPING ENDCAPS

WELDED PRE-FINISHED ENDCAP ASSEMBLY

STANDARD ENDCAP LENGTH IS 18"

1. PAINT IS GROUND OFF EDGES TO BE WELDED

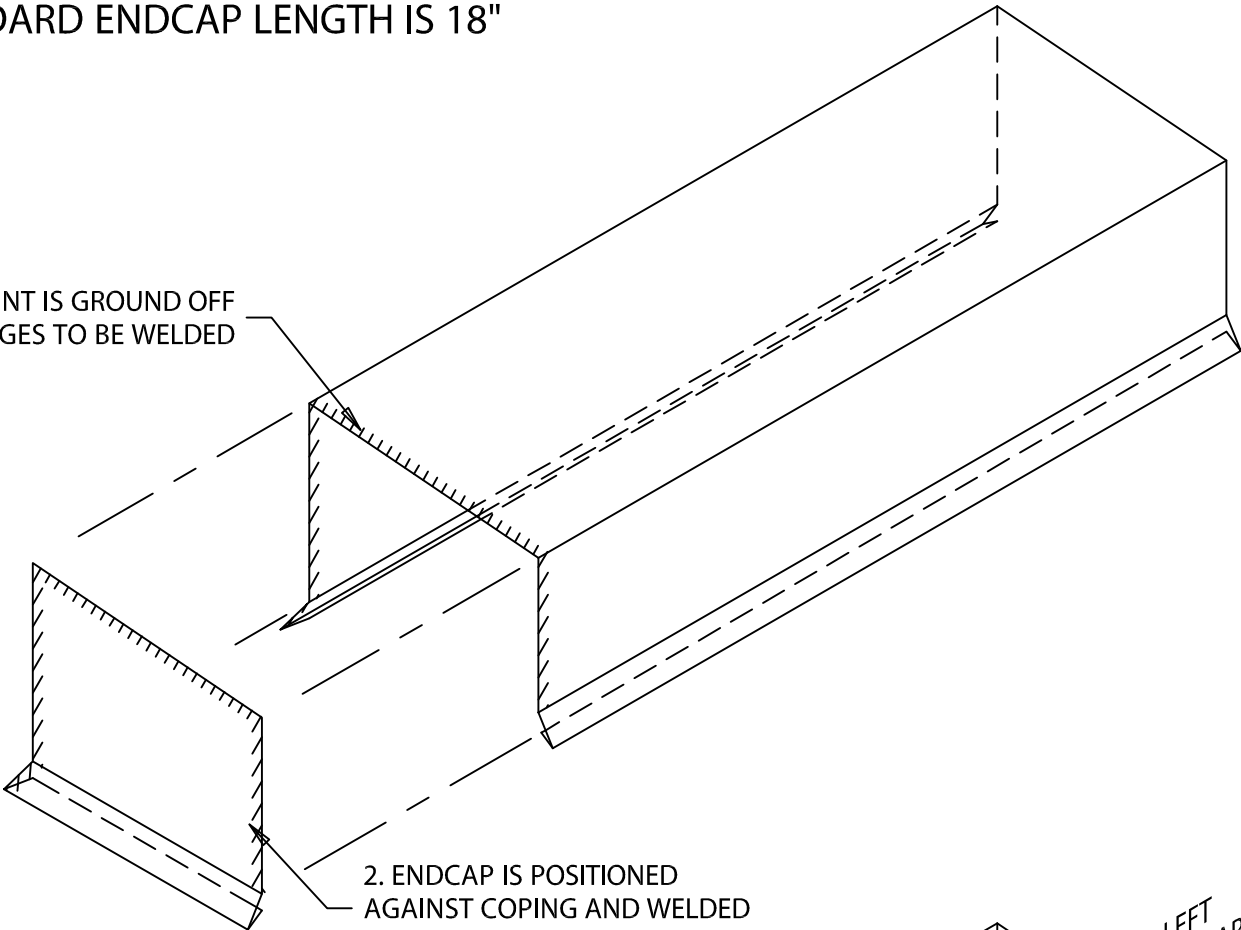

2. ENDCAP IS POSITIONED AGAINST COPING AND WELDED INTO PLACE

3. WELDED AREAS ARE PRIMED AND FINISHED WITH AIR DRY PAINT

OUTSIDE FACE

LEFT ENDCAP

INSIDE FACE

WELDED ENDCAPS ARE FABRICATED WITH FULLY WELDED OUTSIDE CORNERS

