

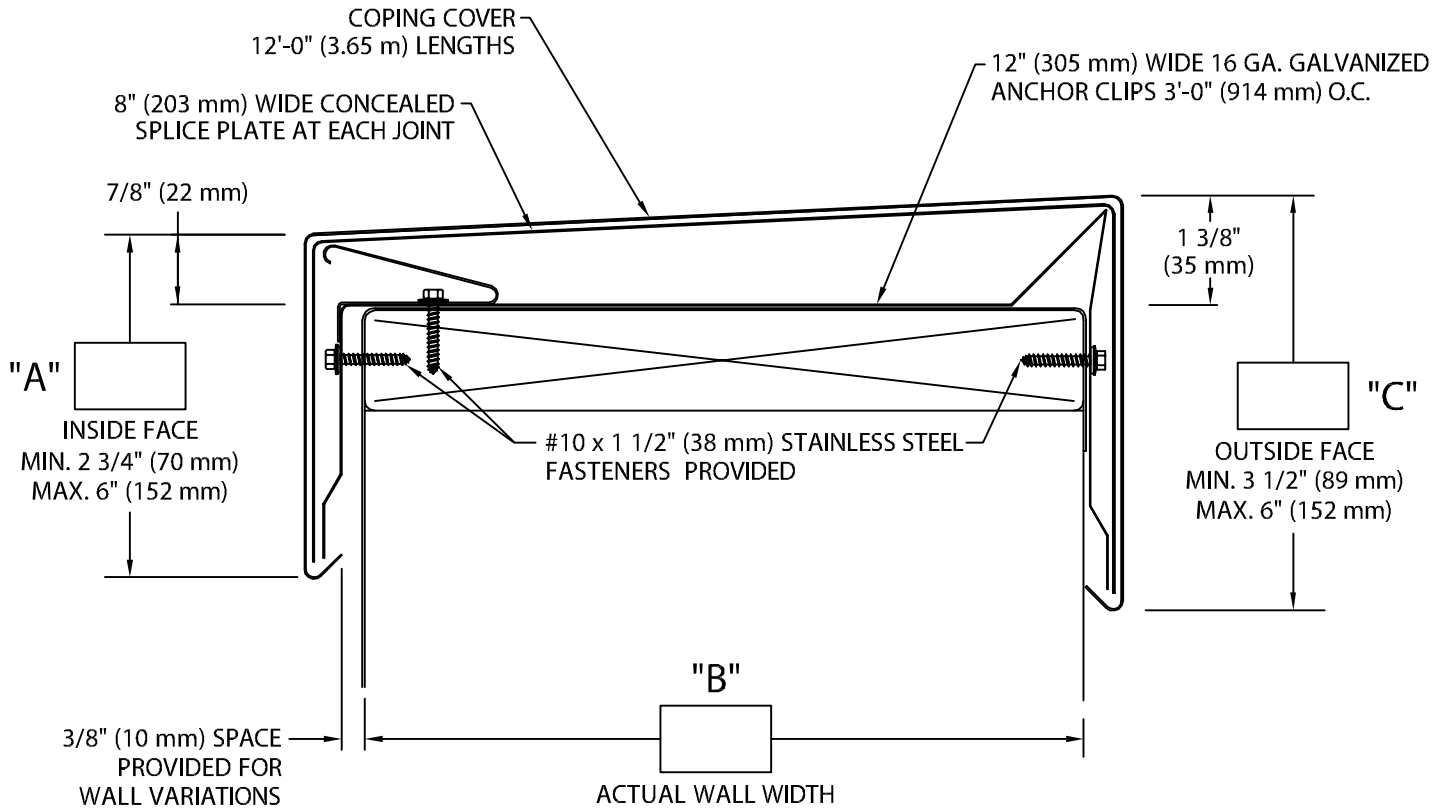

# PAC-TITE GOLD COPING

TAPERED VERSION

24 GA. & .050", UP TO 16" WALL ANSI/SPRI ES-1 DESIGN PRESSURE OF 290 psf



-- Concealed splice plates are provided with factory applied dual non-curing sealant strips.  
 -- Unless otherwise noted, fabrication of miters and accessories are furnished standard utilizing a non-penetrating quicklock joint, then factory sealed watertight.

-- Welded Miters and Accessories  
 Check one  Required (surcharge)  Not applicable

Fabrication will proceed only after receipt of signed print approval.

## Print Approval:

Architect and/or contractor shall verify all dimensions, sizes and quantities. All products to be installed in strict accordance with Petersen Aluminum's printed instructions.

Approved by: \_\_\_\_\_

Date: \_\_\_\_\_

### MATERIAL:

- \_\_\_ 24 Ga. (0.65 mm) Galv.
- \_\_\_ .040" (1.01 mm) Alum.
- \_\_\_ .050" (1.27 mm) Alum. Color: \_\_\_\_\_
- \_\_\_ .063" (1.60 mm) Alum. Finish: \_\_\_\_\_
- \_\_\_ OTHER \_\_\_\_\_

### QUANTITIES:

- \_\_\_\_\_ Lineal Feet 12'-0" (3.65 m) Lengths
- \_\_\_\_\_ Outside Miters @ (\_\_\_\_\_)°
- \_\_\_\_\_ Inside Miters @ (\_\_\_\_\_)°
- \_\_\_\_\_ Right End Caps
- \_\_\_\_\_ Left End Caps

PROJECT:

ARCHITECT:

ROOFING CONTRACTOR:

REPRESENTATIVE/DISTRIBUTOR:



Phone: 800-323-1960 Fax: 800-722-7150  
 www.pac-clad.com  
 e-mail: info@pac-clad.com

DATE: 02/12/13

DRN BY: JJC

CKD BY: SAK

SHT.# \_\_\_ OF \_\_\_

DWG# 41011-17187

A