

PAC-TITE WT FASCIA

FULLY ADHERED OR MECHANICALLY ATTACHED SINGLE-PLY VERSION

ANSI/SPRI ES-1 TESTED

FASCIA COVER
12'-0" (3.65 m)
LENGTHS

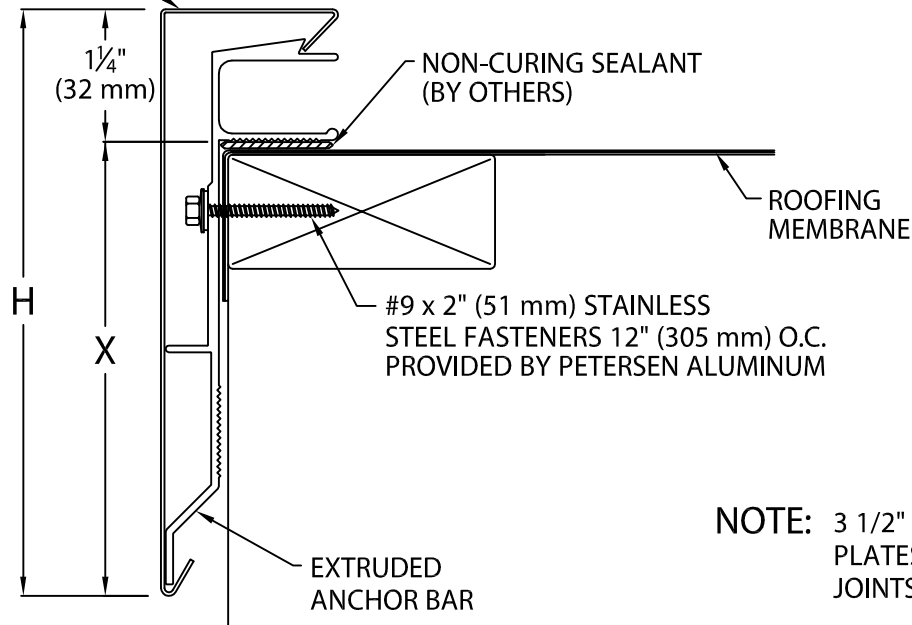

NOTE: 3 1/2" (89 mm) SPLICE
PLATES PROVIDED AT ALL
JOINTS

Fascia is to be installed per Specifications and Petersen Aluminum's Installation Instructions Dwg. # 41110-12126

PAC-TITE WT FASCIA DIMENSIONS

PRODUCT ID. NO.	H DIM	X DIM	NAILER COVERAGE
<input type="checkbox"/> HG-AF-40	4" (102 mm)	2 3/4" (70 mm)	1 NAILER
<input type="checkbox"/> HG-AF-55	5 1/2" (140 mm)	4 1/4" (108 mm)	2 NAILERS
<input type="checkbox"/> HG-AF-70	7" (178 mm)	5 3/4" (146 mm)	3 NAILERS

Fabrication will proceed only after receipt of signed print approval.

Print Approval:

Architect and/or contractor shall verify all dimensions, sizes and quantities. All products to be installed in strict accordance with Petersen Aluminum's printed instructions.

Approved by: _____

Date: _____

MATERIAL:

____ .050" (1.27 mm) Aluminum

____ .063" (1.60 mm) Aluminum

____ OTHER _____

Color: _____

Finish: _____

QUANTITIES:

_____ Lineal Feet 12'-0" (3.65 m) Lengths

_____ Outside Miters @ (____)°

_____ Inside Miters @ (____)°

_____ Overflow Scupper Style ____A____B

_____ Spillout Scupper Style ____A____B

_____ Downspout Scupper Style ____A____B

(____X____) Size A: Tapered 1 1/2" (38 mm) Drop
B: Flat

PROJECT:

ARCHITECT:

ROOFING CONTRACTOR:

REPRESENTATIVE/DISTRIBUTOR:



Phone: 800-323-1960 Fax: 800-722-7150
www.pac-clad.com
e-mail: info@pac-clad.com

DATE: 07/23/10

DRN BY: JJC

CKD BY: SAK

SHT.# ____ OF ____

DWG# 41010-12125

A