

# DOWNSPOUT ELBOWS

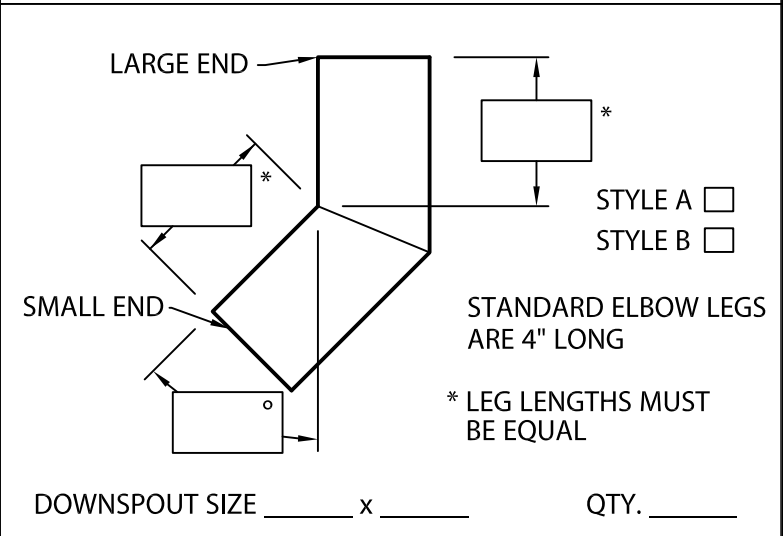
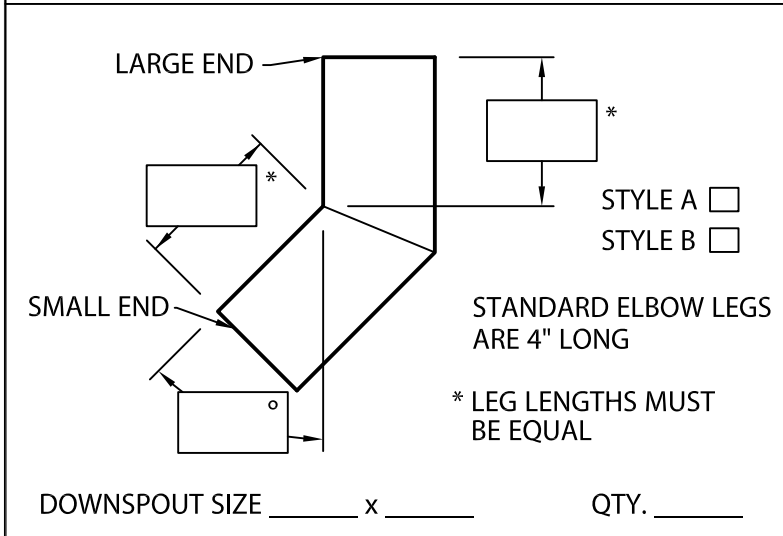
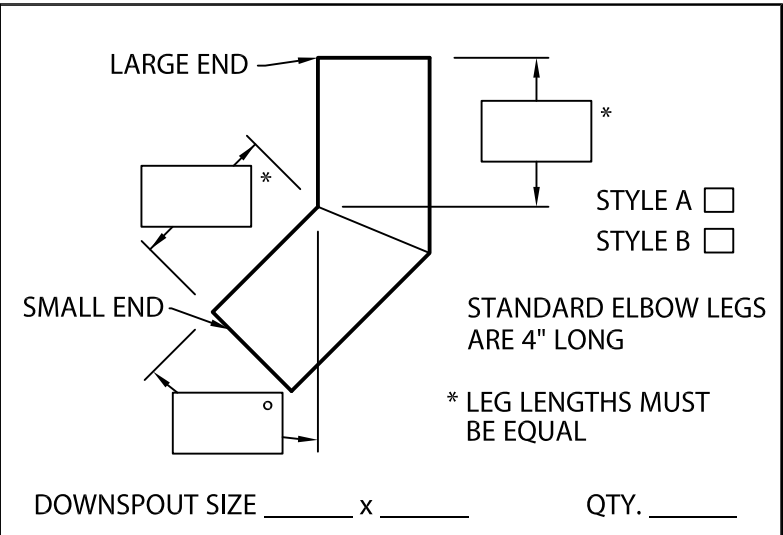
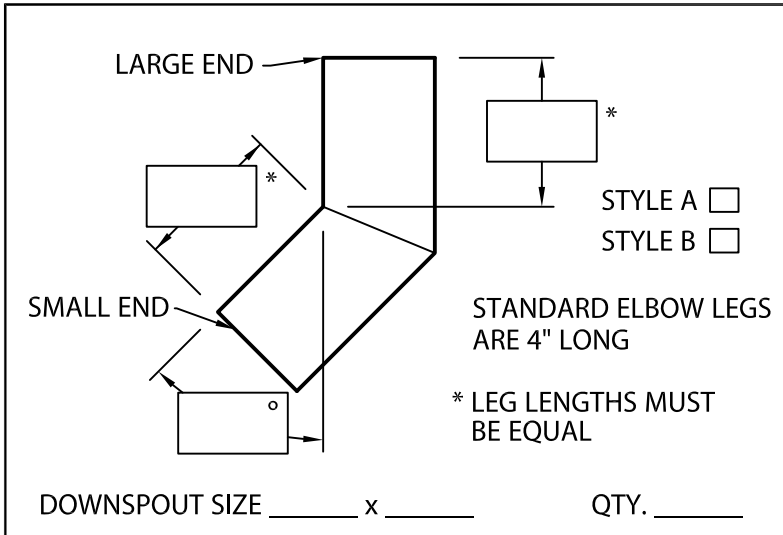

Fabrication will proceed only after receipt of signed print approval.

## Print Approval:

Architect and/or contractor shall verify all dimensions, sizes and quantities. All products to be installed in strict accordance with Petersen Aluminum's printed instructions.

Approved by: \_\_\_\_\_

Date: \_\_\_\_\_

## MATERIAL:

- \_\_\_ 24 Ga. (.65 mm) Galv.
- \_\_\_ .040" (1.01 mm) Alum.
- \_\_\_ .050" (1.27 mm) Alum.
- \_\_\_ .063" (1.60 mm) Alum.
- \_\_\_ OTHER \_\_\_\_\_

Color: \_\_\_\_\_

Finish: \_\_\_\_\_

PROJECT:

ARCHITECT:

ROOFING CONTRACTOR:

REPRESENTATIVE/DISTRIBUTOR:



Phone: 800-323-1960 Fax: 800-722-7150  
 www.pac-clad.com  
 e-mail: info@pac-clad.com

DATE: 03/18/21

DRN BY: ZS

CKD BY: MM

SHT.# \_\_\_ OF \_\_\_

DWG# 41013-35946

A