

DOWNSPOUT TRANSITION

ISOMETRIC VIEW

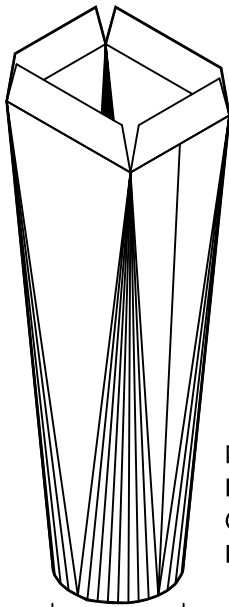

FRONT VIEW

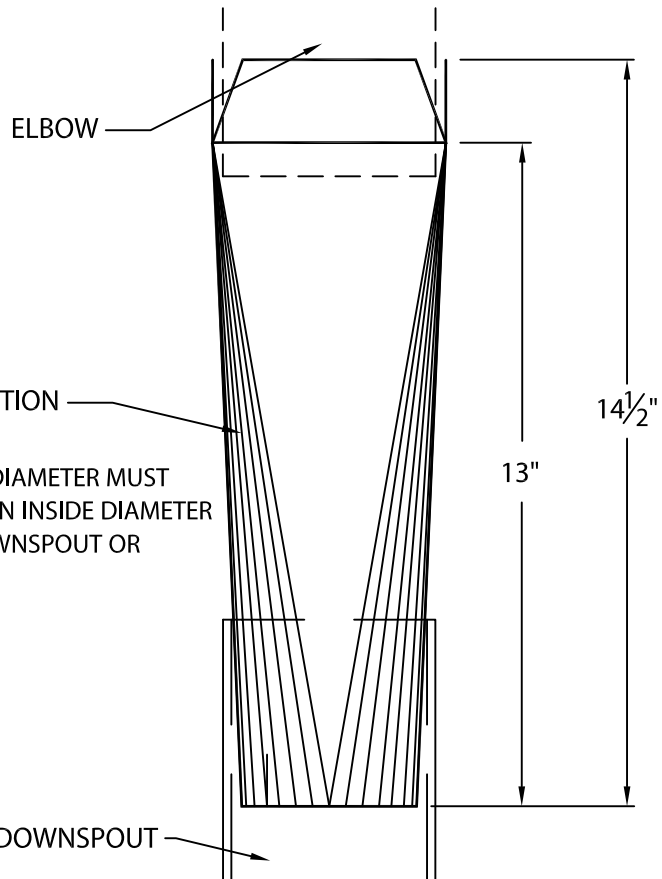

NOTE: OUTSIDE DIAMETER MUST BE SMALLER THAN INSIDE DIAMETER OF EXISTING DOWNSPOUT OR PVC PIPE

FRONT VIEW

SPECIFY OUTSIDE DIAMETER

EXISTING DOWNSPOUT

-- WELDED SEAM OR QUICKLOCK SEAM
CHECK ONE WELDED QUICKLOCK

Fabrication will proceed only after receipt of signed print approval.

Print Approval:

Architect and/or contractor shall verify all dimensions, sizes and quantities. All products to be installed in strict accordance with Petersen Aluminum's printed instructions.

Approved by: _____

Date: _____

MATERIAL:

__ 24 GA. GALVANIZED STEEL __ .050" ALUMINUM

__ .040" ALUMINUM __ .063" ALUMINUM

__ OTHER: _____

COLOR: _____ FINISH: _____

QUANTITIES:

_____ AMOUNT REQUIRED*

DOWNSPOUT SIZE _____" x _____"

*WELDED VERSION WITH QUANTITIES OVER 15 REQUIRE AN EXTENDED LEAD TIME DUE TO POST COATING PROCESS.

PROJECT:

ARCHITECT:

ROOFING CONTRACTOR:

REPRESENTATIVE/DISTRIBUTOR:



Phone: 800-323-1960 Fax: 800-722-7150
www.pac-clad.com
e-mail: info@pac-clad.com

DATE: 11/28/16

DRN BY: JJC

CKD BY: SAK

SHT.# ___ OF ___

DWG# 41013-15373

