



# PAC-TITE GOLD GUTTER

24 GA. / .040" MATERIAL ANSI/SPRI GT-1 TESTED 150 LBS / SQ FT

IGG-1 VERSION

.050" / .063" MATERIAL ANSI/SPRI GT-1 TESTED 210 LBS / SQ FT

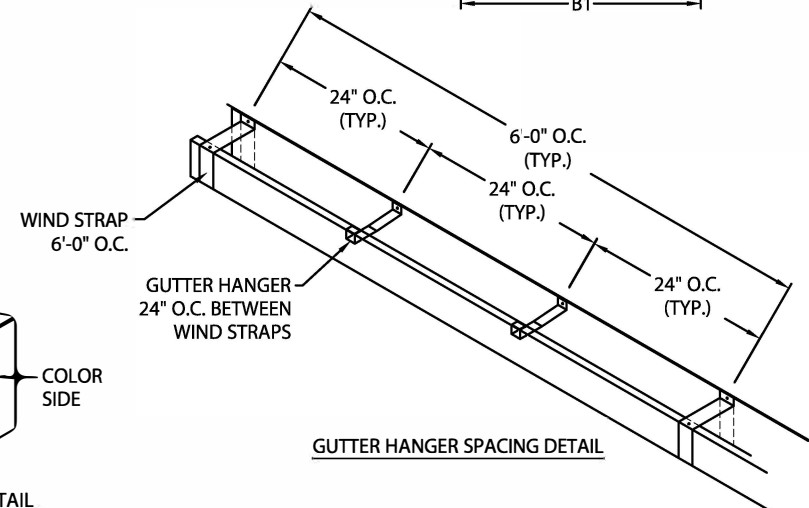
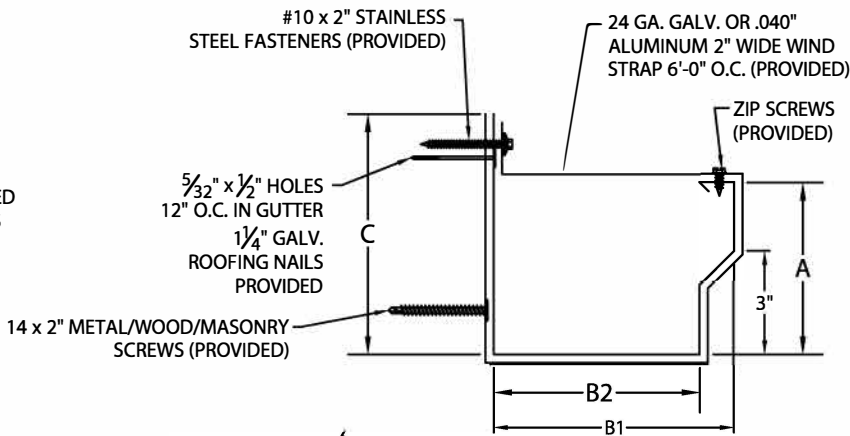
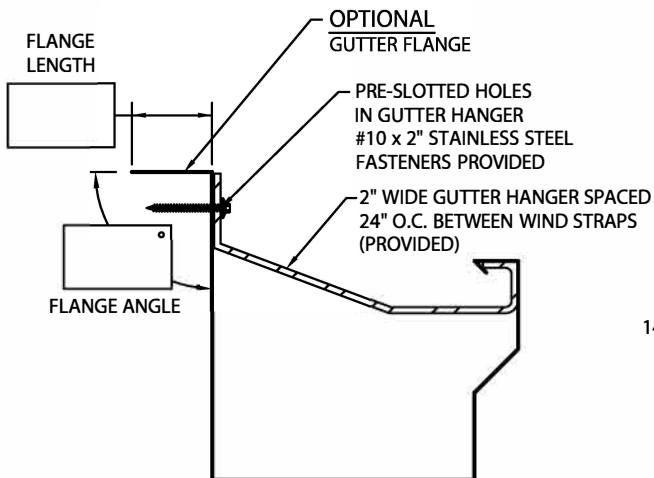

PRODUCT ID #	C	B1	B2	A
<input type="checkbox"/> IGG1-C6	6"	4 3/4"	3 3/4"	4 1/2"
<input type="checkbox"/> IGG1-C7	7"	6"	5"	6"
<input type="checkbox"/> IGG1-C8	8"	7"	6"	7"
<input type="checkbox"/> IGG1-C9	9"	8"	7"	8"

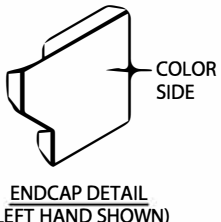

**NOTES:**  
 -- MAXIMUM DOWNSPOUT DIMENSION NOT TO EXCEED "B2" MINUS 9/16".  
 -- 6" WIDE SPLICE PLATES PROVIDED.  
 -- 1/8" STAINLESS STEEL POP RIVETS PROVIDED.  
 -- UNLESS OTHERWISE NOTED, FABRICATION OF MITERS ARE FURNISHED STANDARD UTILIZING A NON-PENETRATING QUICKLOCK JOINT, THEN FACTORY SEALED WATERTIGHT.  
 -- WELDED ACCESSORIES REQUIRE A MINIMUM MATERIAL THICKNESS OF .050".

**MATERIAL:**  
 \_\_\_ 24 GA. GALVANIZED STEEL  
 \_\_\_ .040" ALUMIINUM COLOR: \_\_\_\_\_  
 \_\_\_ .050" ALUMINUM FINISH: \_\_\_\_\_  
 \_\_\_ .063" ALUMINUM  
 \_\_\_ OTHER \_\_\_\_\_

Fabrication will proceed only after receipt of signed print approval.  
**Print Approval:**  
 Architect and/or contractor shall verify all dimensions, sizes and quantities. All products to be installed in strict accordance with Petersen Aluminum's printed instructions.  
 Approved by: \_\_\_\_\_  
 Date: \_\_\_\_\_

**QUANTITIES:**  
 \_\_\_\_\_ LINEAL FEET 12'-0" LENGTHS  
 \_\_\_\_\_ OUTSIDE MITERS @ 90°  
 \_\_\_\_\_ INSIDE MITERS @ 90°  
 \_\_\_\_\_ RIGHT ENDCAPS  
 \_\_\_\_\_ LEFT ENDCAPS  
 \_\_\_\_\_ EXPANSION JOINTS STYLE "1"  
 \_\_\_\_\_ EXPANSION JOINTS STYLE "2"  
 SPECIFY MITER TYPE:  
 WELDED  
 QUICKLOCK  
 FOR NON-90 MITERS SEE PRINT APPROVAL #41012-15305

**PROJECT:** \_\_\_\_\_  
**ARCHITECT:** \_\_\_\_\_  
**ROOFING CONTRACTOR:** \_\_\_\_\_  
**REPRESENTATIVE/DISTRIBUTOR:** \_\_\_\_\_



Phone: 800-323-1960 Fax: 800-722-7150  
 www.pac-clad.com  
 e-mail: info@pac-clad.com

DATE: 03/18/21  
 DRN BY: ZS  
 CKD BY: MM

SHT.# \_\_\_\_\_ OF \_\_\_\_\_  
 DWG# 41012-35930 **A**