

# PAC-TITE GOLD GUTTER

24 GA. / .040" MATERIAL ANSI/SPRI GT-1 TESTED 150 LBS / SQ FT

IGG-3 VERSION

.050" / .063" MATERIAL ANSI/SPRI GT-1 TESTED 210 LBS / SQ FT

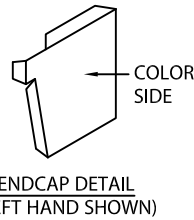
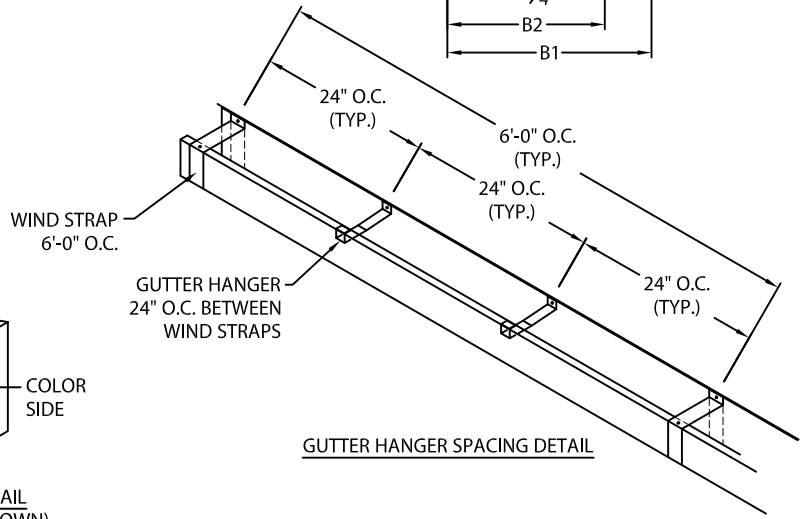
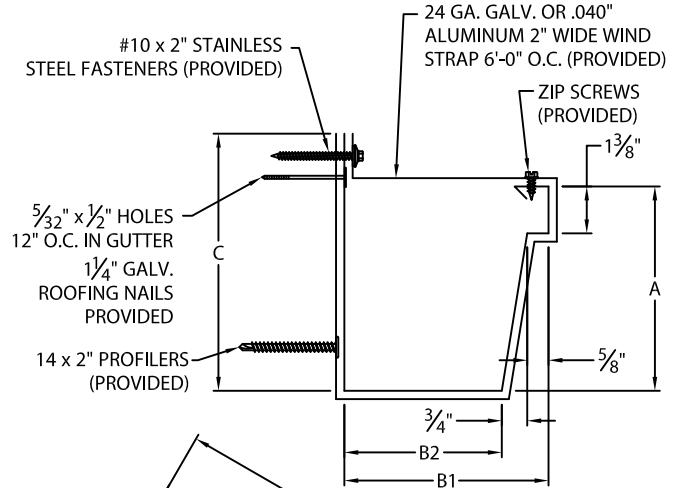
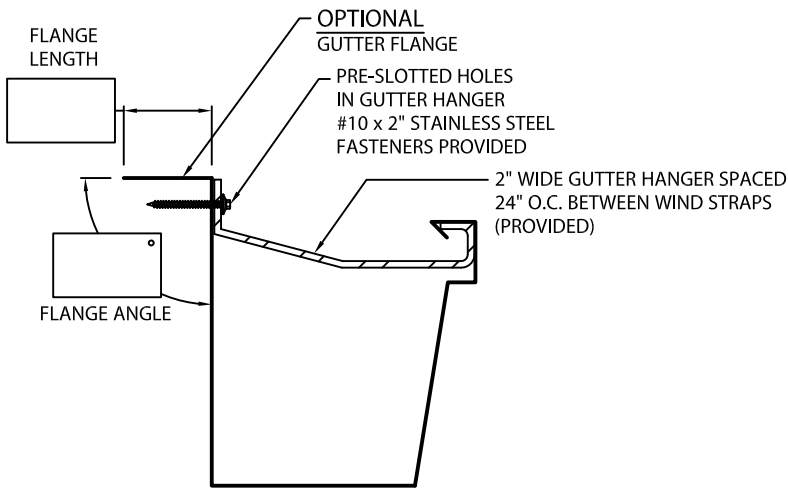

PRODUCT ID #	C	B1	B2	A
<input type="checkbox"/> IGG3-C6	6"	5"	3 5/8"	5"
<input type="checkbox"/> IGG3-C7	7"	6"	4 5/8"	6"
<input type="checkbox"/> IGG3-C8	8"	7"	5 5/8"	7"
<input type="checkbox"/> IGG3-C9	9"	8"	6 5/8"	8"

**NOTES:**

- MAXIMUM DOWNSPOUT DIMENSION NOT TO EXCEED "B2" MINUS 9/16".
- 6" WIDE SPLICE PLATES PROVIDED.
- 1/8" STAINLESS STEEL POP RIVETS PROVIDED.
- UNLESS OTHERWISE NOTED, FABRICATION OF MITERS ARE FURNISHED STANDARD UTILIZING A NON-PENETRATING QUICKLOCK JOINT, THEN FACTORY SEALED WATERTIGHT.
- WELDED ACCESSORIES REQUIRE A MINIMUM MATERIAL THICKNESS OF .050".

Fabrication will proceed only after receipt of signed print approval.

**Print Approval:**

Architect and/or contractor shall verify all dimensions, sizes and quantities. All products to be installed in strict accordance with Petersen Aluminum's printed instructions.

Approved by: \_\_\_\_\_

Date: \_\_\_\_\_

**MATERIAL:**

- \_\_\_ 24 GA. GALVANIZED STEEL
- \_\_\_ .040" ALUMIINUM COLOR: \_\_\_\_\_
- \_\_\_ .050" ALUMINUM FINISH: \_\_\_\_\_
- \_\_\_ .063" ALUMINUM
- \_\_\_ OTHER \_\_\_\_\_

**QUANTITIES:**

- \_\_\_ LINEAL FEET 12'-0" LENGTHS
  - \_\_\_ OUTSIDE MITERS @ 90°
  - \_\_\_ INSIDE MITERS @ 90°
  - \_\_\_ RIGHT ENDCAPS
  - \_\_\_ LEFT ENDCAPS
  - \_\_\_ EXPANSION JOINTS STYLE "1"
  - \_\_\_ EXPANSION JOINTS STYLE "2"
- SPECIFY MITER TYPE:  
 WELDED  
 QUICKLOCK

FOR NON-90 MITERS SEE PRINT APPROVAL #41012-15305

**PROJECT:**

**ARCHITECT:**

**ROOFING CONTRACTOR:**

**REPRESENTATIVE/DISTRIBUTOR:**



Phone: 800-323-1960 Fax: 800-722-7150  
 www.pac-clad.com  
 e-mail: info@pac-clad.com

DATE: 03/18/21  
 DRN BY: ZS  
 CKD BY: MM

SHT.# \_\_\_\_ OF \_\_\_\_  
 DWG# 41012-35517

**B**