

PAC-TITE LT HALF ROUND GUTTER

VERTICAL FASCIA VERSION

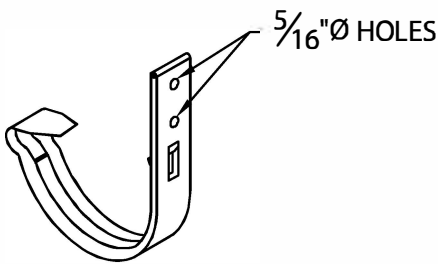

EXTERNAL GUTTER BRACKET DETAIL

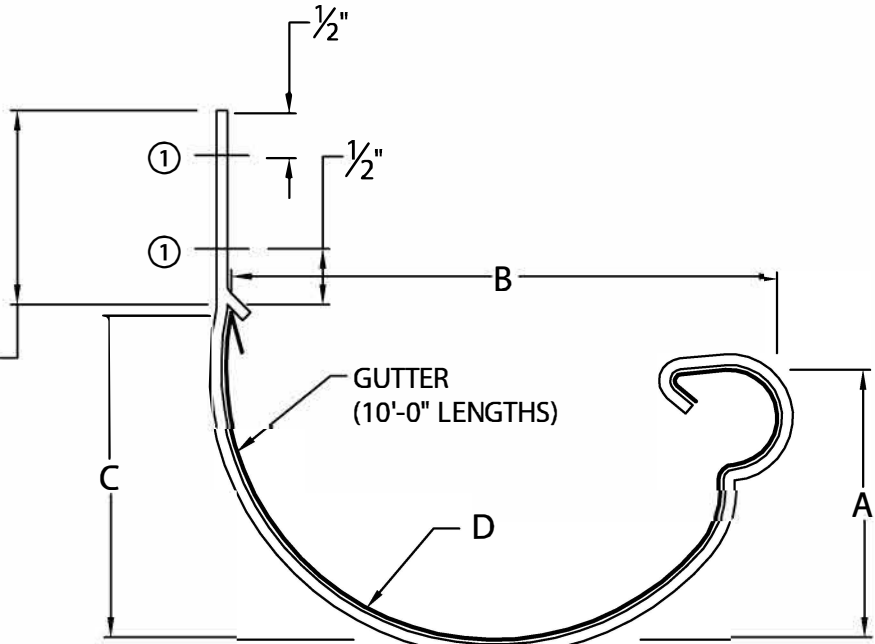
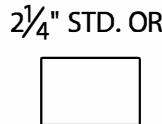

3/16" x 1" STAINLESS BRACKET WRAPPED IN METAL TO MATCH GUTTER
 5"Ø & 6"Ø - 36" O.C.
 7"Ø, 8"Ø, 9"Ø & 10"Ø - 24" O.C.

GUTTER DIAMETER	A	B	C	D
<input type="checkbox"/> 5"Ø ②	2 1/2"	5 1/4"	3"	2 1/2" RADIUS
<input type="checkbox"/> 6"Ø	3"	6 1/4"	3 1/2"	3" RADIUS
<input type="checkbox"/> 7"Ø	3 1/2"	7 1/4"	4"	3 1/2" RADIUS
<input type="checkbox"/> 8"Ø	4"	8 1/4"	4 1/2"	4" RADIUS
<input type="checkbox"/> 9"Ø	4 1/2"	9 1/4"	5"	4 1/2" RADIUS
<input type="checkbox"/> 10"Ø	5"	10 1/4"	5 1/2"	5" RADIUS

- ① #10 x 1 1/2" STAINLESS STEEL FASTENERS (PROVIDED)
- ② THIS SIZE NOT AVAILABLE IN 22 GA. GALV. STEEL OR .050" ALUM.

MATERIAL:

- ___ 24 GA. GALV. STEEL ③
 - ___ 22 GA. GALV. STEEL ② ③
 - ___ .032" ALUMINUM ③
 - ___ .040" ALUMINUM ③
 - ___ .050" ALUMINUM ② ④
 - OTHER _____
- COLOR: _____
 FINISH: _____

QUANTITIES:

- ___ LINEAL FEET 10'-0" LENGTHS
 - ___ OUTSIDE MITERS @ 90°
 - ___ INSIDE MITERS @ 90°
 - ___ ENDCAPS: RIGHT _____ LEFT _____
- FOR NON-90 MITERS SEE PRINT APPROVAL

NOTES:
 -- MATERIAL PROVIDED WITH 6" WIDE SPLICE PLATES. ④
 -- MATERIAL NEEDS FIELD NOTCHED LAP JOINTS. ③
 -- 1/8" STAINLESS STEEL POP RIVETS PROVIDED.
 -- UNLESS OTHERWISE NOTED, FABRICATION OF MITERS ARE FURNISHED STANDARD UTILIZING POP RIVETS, THEN FACTORY SEALED WATERTIGHT.
 -- WELDED ACCESSORIES REQUIRE A MINIMUM MATERIAL THICKNESS OF .050".

AUTHORIZED SIGNATURE:
APPROVED BY: _____
DATE: _____

PROJECT: _____
ARCHITECT: _____
ROOFING CONTRACTOR: _____
REPRESENTATIVE/DISTRIBUTOR: _____

Phone: 800-323-1960 Fax: 800-722-7150
 www.pac-clad.com
 e-mail: info@pac-clad.com



DATE 06/07/21
 DRN BY: JJC
 CKD BY: MM

SHT. # ___ OF ___
 DWG# 41012-36353