

INSIDE CORNER FLASHING

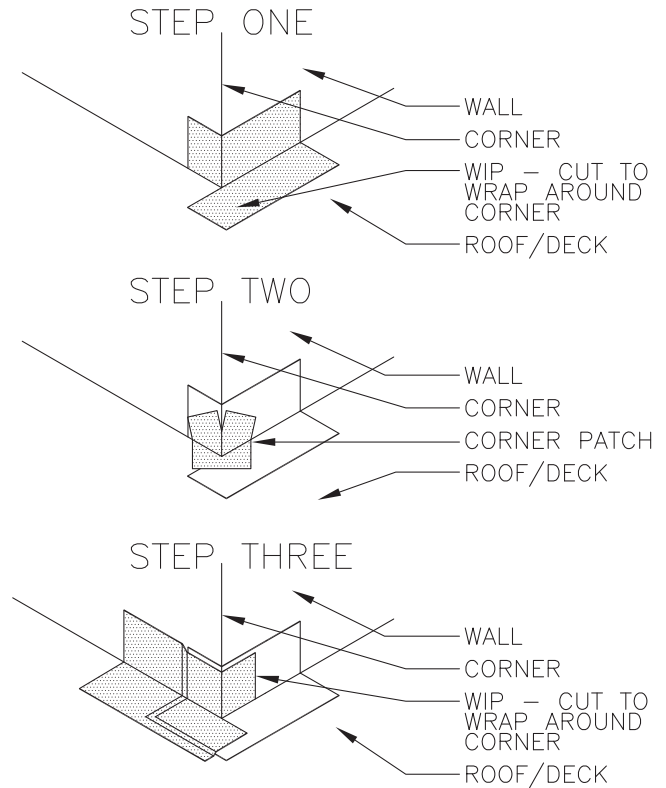

OUTSIDE CORNER FLASHING

NOTES:

1. THE SUBSTRATE HAS TO BE CLEAN AND DRY.
2. RELEASE PAPER IS REMOVED AT TIME OF INSTALLATION.
3. ALL MASONRY OR CONCRETE HAS TO BE PRIMED.
4. WORK FROM BOTTOM OF SLOPE UP THE ROOF TO FORM WATER SHEDDING LAPS.
5. MODIFY RELIEF CUTS IN PATCH AS REQUIRED.

JOB NAME	NOTES
DATE	
CONTRACTOR	

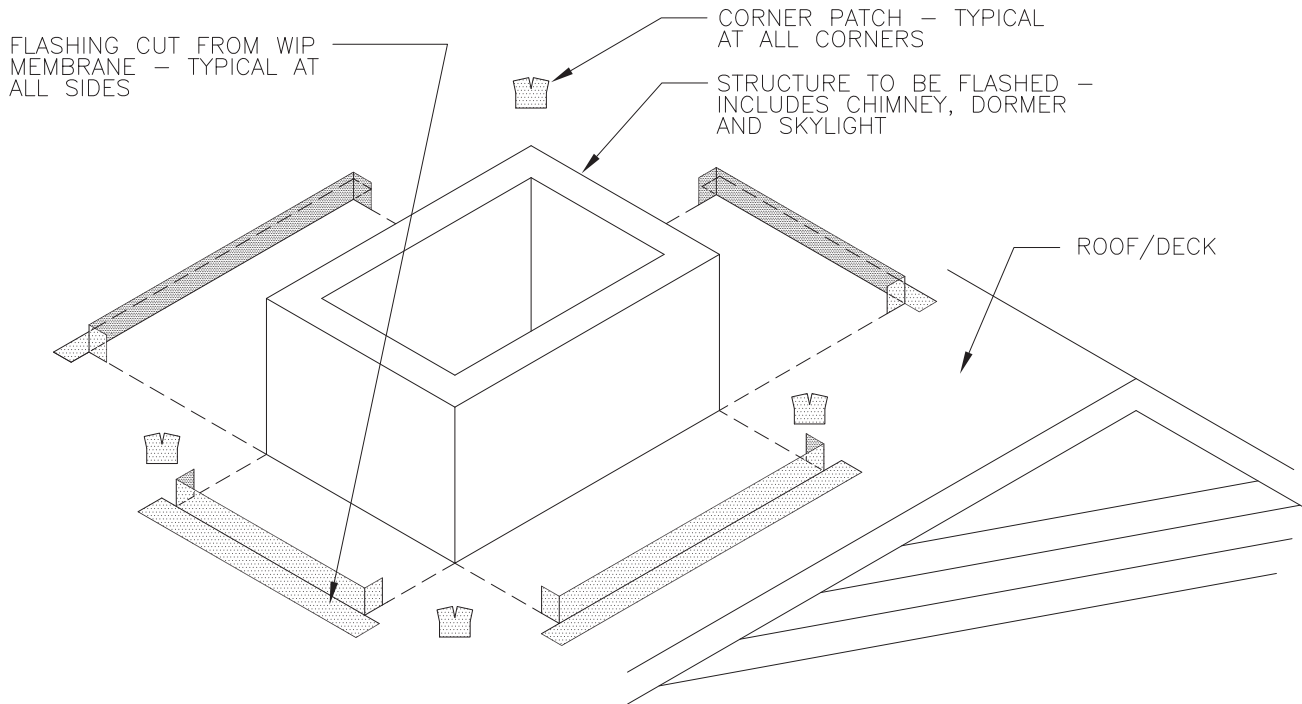

NOTES:

1. THE SUBSTRATE HAS TO BE CLEAN AND DRY.
2. RELEASE PAPER IS REMOVED AT TIME OF INSTALLATION.
3. ALL MASONRY OR CONCRETE HAS TO BE PRIMED.
4. WORK FROM BOTTOM OF SLOPE UP THE ROOF TO FORM WATER SHEDDING LAPS.
5. MODIFY RELIEF CUTS IN PATCH AS REQUIRED.
6. COVER ALL EXPOSED FLASHING WITH METAL FLASHING, SIDING OR SHINGLES/ ROOF COVERING.

JOB NAME	NOTES
DATE	
CONTRACTOR	