

# FLUSH & REVEAL - WOOD SUBSTRATE DETAILS

## WINDOW JAMB DETAIL

### VERTICAL APPLICATION



THIS DETAIL DRAWING IS APPLICABLE TO ALL FLUSH & REVEAL SERIES WALL PANEL PROFILES

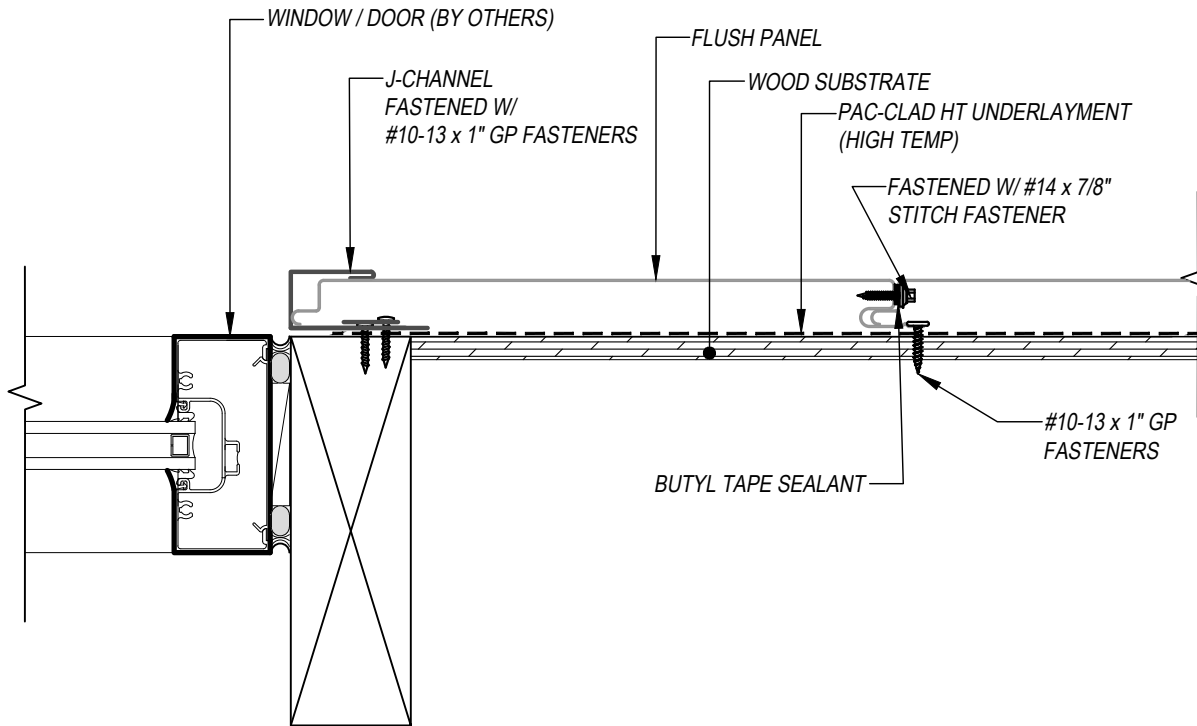

**KEYNOTES:**

- TRIM FASTENERS ARE SELF-DRILL PANCAKE HEAD AND MUST BE INSTALLED IN A STAGGERED PATTERN
- FASTENERS MUST PENETRATE WOOD SUBSTRATE BY 5/8" MINIMUM THREAD LENGTH
- FASTENER SPACING VARIES BASED ON PROJECT SPECIFIC LOADS AND/OR LOCAL BUILDING CODES

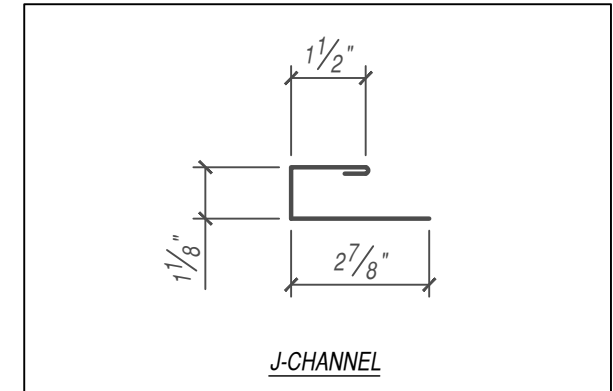

SCALE: 3" = 1'-0"

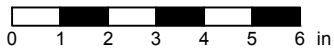

EFFECTIVE DATE: 01-03-2023  
SUBJECT TO CHANGE WITHOUT NOTICE

DISCLAIMER: DETAIL SHOWN FOR ILLUSTRATION PURPOSES ONLY. ACTUAL PROJECT DETAIL MAY VARY