

COMPOSITE WALL - PAC-3000 CS - WOOD SUBSTRATE DETAILS

VERTICAL JOINT

* CALL FOR RECOMENDATION ON TYPE OF SILICONE SEALANT

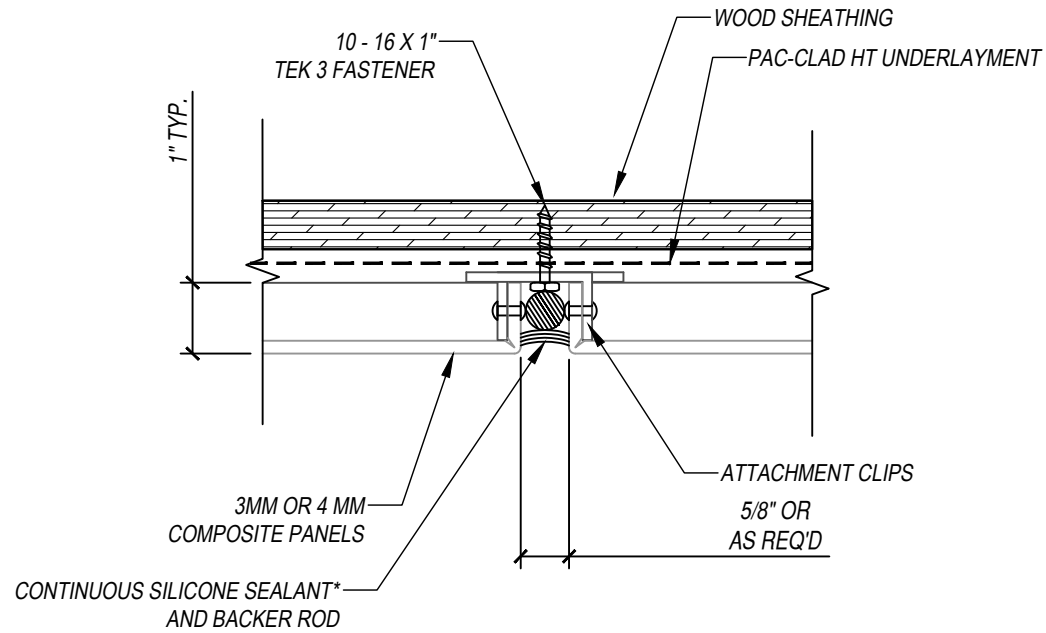

SCALE: 3" = 1'-0"

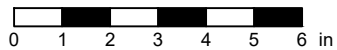

EFFECTIVE DATE: 01-03-2023

SUBJECT TO CHANGE WITHOUT NOTICE

DISCLAIMER: DETAIL SHOWN FOR ILLUSTRATION PURPOSES ONLY. ACTUAL PROJECT DETAIL MAY VARY

PETERSEN ALUMINUM CORPORATION - PAC-CLAD.COM

SALES@PETERSENMAIL.COM

HQ: 1005 Tonne Road
Elk Grove Village, IL 60007
P: 800-PAC-CLAD
F: 800-722-7150

9060 Junction Drive
Annapolis Junction, MD 20701
P: 800-344-1400
F: 301-953-7627

10551 PAC Road
Tyler, TX 75707
P: 800-441-8661
F: 903-581-8592

102 Northpoint Parkway
Acworth, GA 30102
P: 800-272-4482
F: 770-420-2533

1800 S. 7th Ave., Suite 130
Phoenix, AZ 85007
P: 833-750-1935
F: 602-254-6504

9817 233rd Ave. E, Suite A
Bonney Lake, WA 98391
P: 253-501-2450
F: N/A