

PRECISION SERIES TILE - WOOD SUBSTRATE DETAILS WINDOW HEAD DETAIL

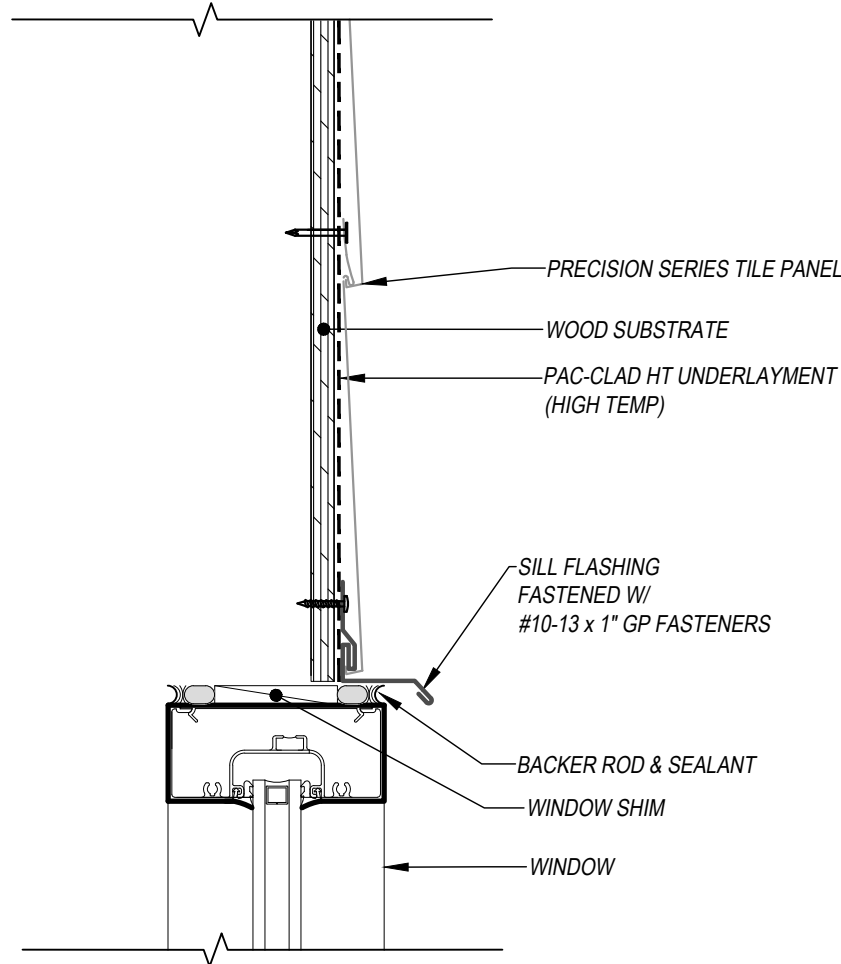

PRECISION SERIES TILE



SCALE: 3" = 1'-0"

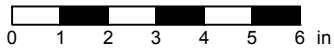

EFFECTIVE DATE: 01-03-2023
SUBJECT TO CHANGE WITHOUT NOTICE

THIS DETAIL DRAWING IS APPLICABLE TO ALL PRECISION SERIES TILE WALL PANEL PROFILES

FLAT TILE



CUPPED TILE

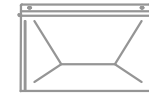

DIAMOND TILE



KEYNOTES:

- TRIM FASTENERS ARE SELF-DRILL PANCAKE HEAD AND MUST BE INSTALLED IN A STAGGERED PATTERN
- FASTENERS MUST PENETRATE WOOD SUBSTRATE BY 5/8" MINIMUM THREAD LENGTH
- FASTENER SPACING VARIES BASED ON PROJECT SPECIFIC LOADS AND/OR LOCAL BUILDING CODES

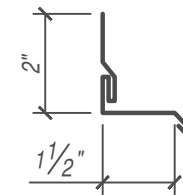

SILL @ WINDOW HEAD

FLASHINGS

DISCLAIMER: DETAIL SHOWN FOR ILLUSTRATION PURPOSES ONLY. ACTUAL PROJECT DETAIL MAY VARY