

# SNAP CLAD - WOOD SUBSTRATE DETAILS SLOPE CHANGE - OPTION 1

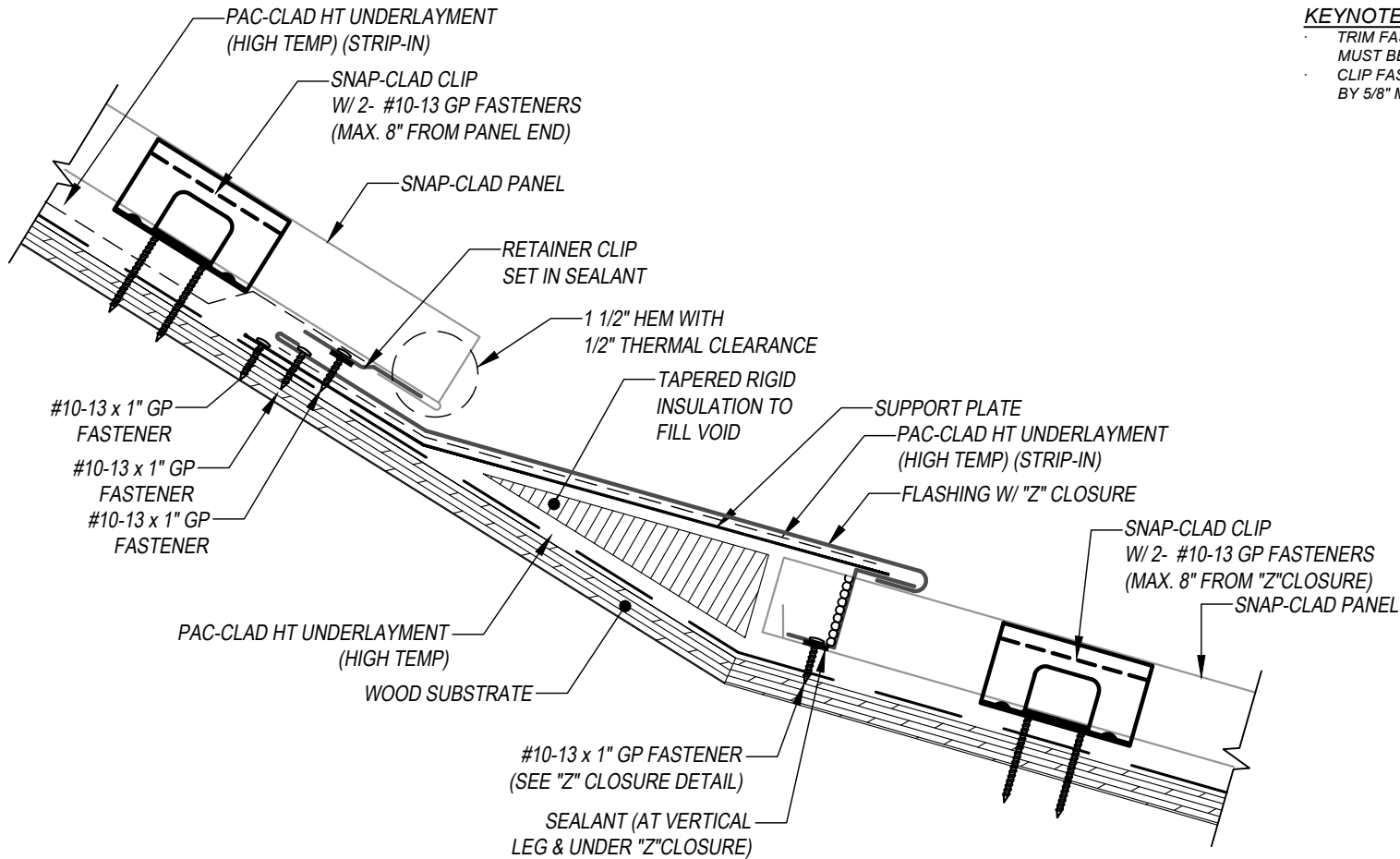

**KEYNOTES:**

- TRIM FASTENERS ARE SELF-DRILL PANCAKE HEAD AND MUST BE INSTALLED IN A STAGGERED PATTERN
- CLIP FASTENERS MUST PENETRATE WOOD SUBSTRATE BY 5/8" MINIMUM THREAD LENGTH

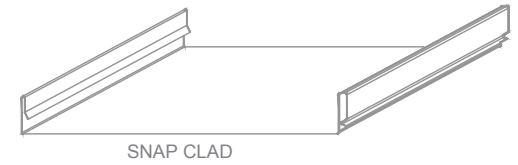
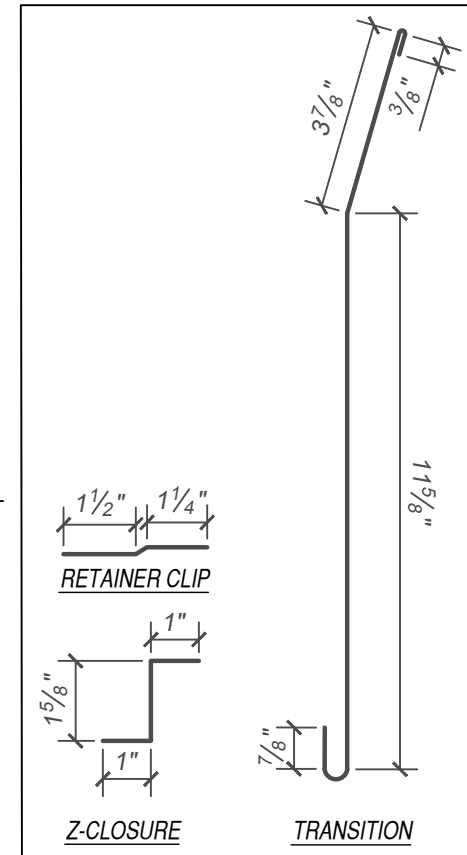

SCALE: 3" = 1'-0"

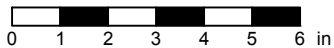

EFFECTIVE DATE: 01-03-2023  
SUBJECT TO CHANGE WITHOUT NOTICE

DISCLAIMER: DETAIL SHOWN FOR ILLUSTRATION PURPOSES ONLY. ACTUAL PROJECT DETAIL MAY VARY