

SNAP CLAD - WOOD SUBSTRATE DETAILS VENTED RIDGE - OPTION 1 (PERFORATED COMPONENT)

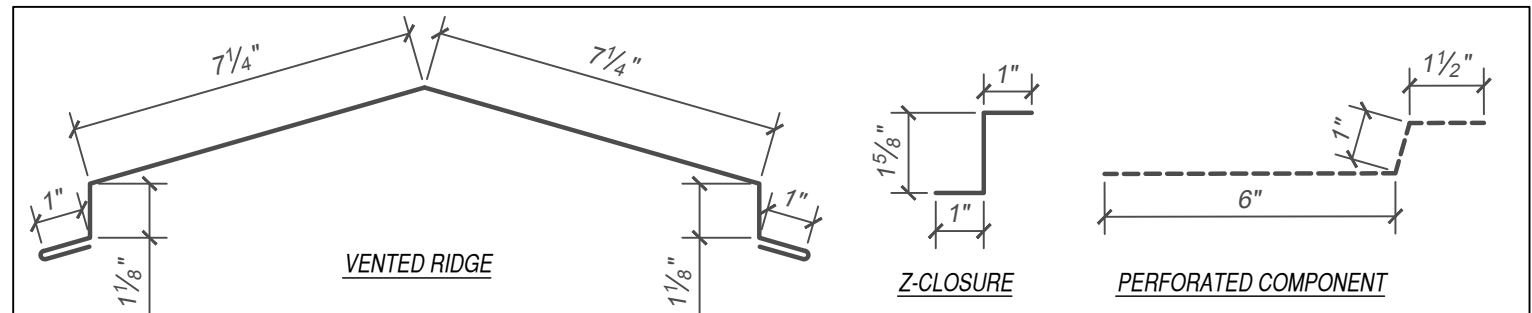

SCALE: 3" = 1'-0"

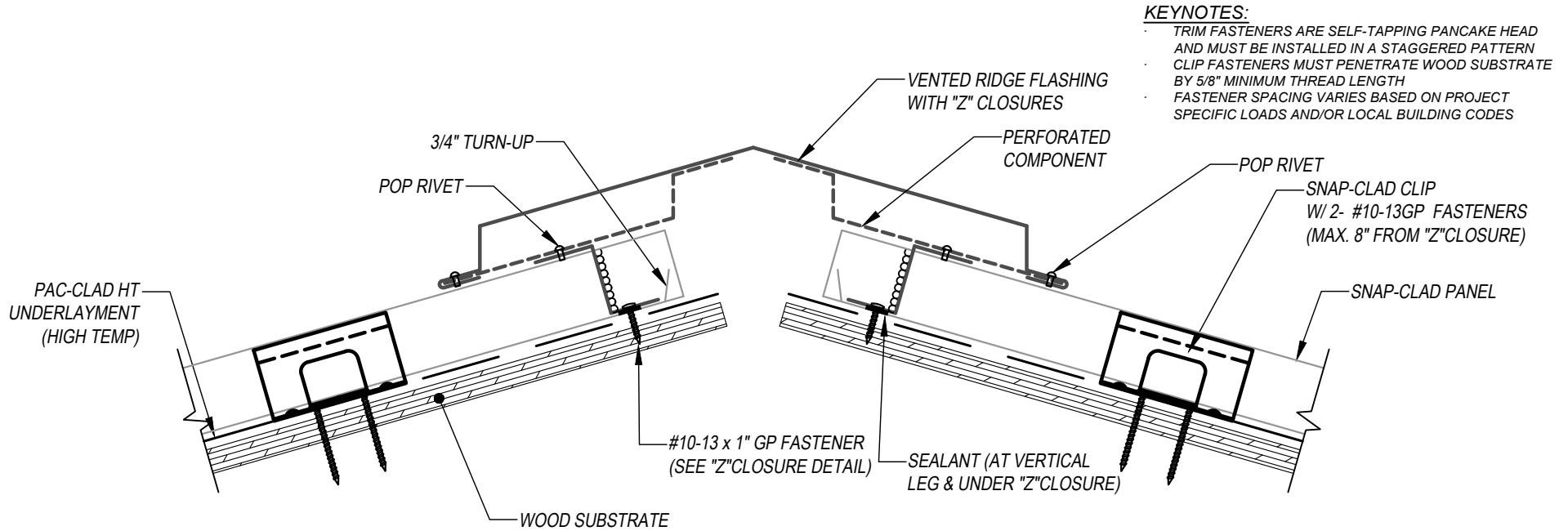
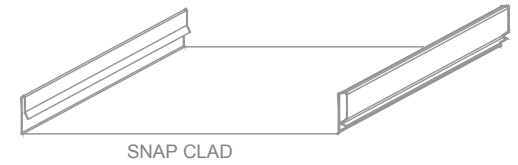
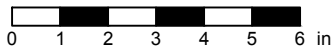

EFFECTIVE DATE: 01-03-2023
 SUBJECT TO CHANGE WITHOUT NOTICE

DISCLAIMER: DETAIL SHOWN FOR ILLUSTRATION PURPOSES ONLY. ACTUAL PROJECT DETAIL MAY VARY