

# Section 1:

## Pre-Fabrication Guidelines



**WARNING: FAILURE TO FOLLOW THESE GUIDELINES  
WILL VOID THE STANDARD WARRANTY.**



BE SURE TO READ, UNDERSTAND AND FOLLOW ALL GUIDELINES. Manufacturer guidelines may vary depending upon specific application and project conditions. The manufacturer should be contacted with questions regarding conditions which vary from the guidelines set forth. Standard carpentry knowledge is required and good construction practice for health, safety and welfare must be followed when fabricating PAC-4000. Citadel Architectural Products offers these recommended guidelines based upon current product information and accepts no responsibility for the conditions and/ or methods of fabrication.

### PRE-FABRICATION: MATERIAL RECEIVING & INVENTORY

#### VISUAL INSPECTION:

Upon material arrival, all panel units and accessory cartons should be visually inspected to verify that the product is in good condition and free from shipping damage, weather damage or defects.

- IS THE PRODUCT IN GOOD CONDITION?**
- IS THE PRODUCT FREE FROM DEFECTS?**
- IS THE PRODUCT CLEAN AND DRY?**

#### NOTE:

- Shipping damage and/or packaging issues should be first noted on the bill of lading and then reported to the manufacturer.
- Should damage occur, the customer is responsible for filing a freight claim with the shipping company **WITHIN 24 HOURS** from material receipt. Failure to do so may possibly result in forfeit of corrective action.
- Any defective material should be reported directly to the manufacturer.

#### MATERIAL INVENTORY:

After verifying the condition of the product, inventory units against the packing slip to make sure that all material (including molding and accessory units) is received.

#### NOTE:

**Notify the manufacturer of any missing or incomplete shipments IMMEDIATELY. Failure to do so may result in forfeit of corrective action.**

- ARE ALL OF THE PANEL UNITS PRESENT?**
- ...THE ACCESSORY UNITS?**
- IS THE PIECE PER UNIT COUNT CORRECT?**

FIGURE A.

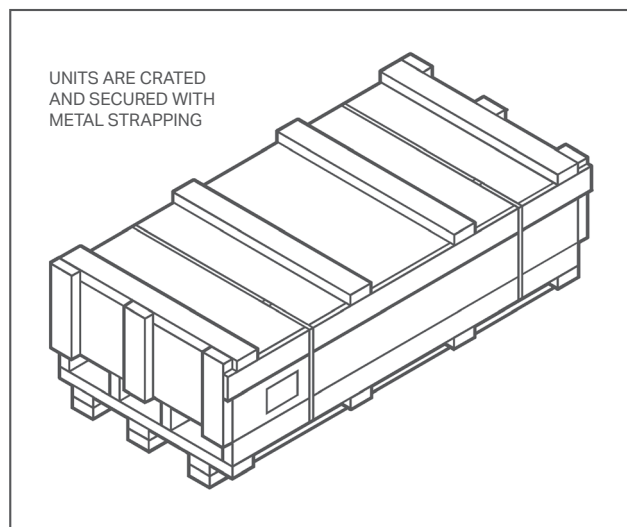

### PRE-FABRICATION: TRANSPORTING & HANDLING

#### TRANSPORTING THE MATERIAL:

PAC-4000 is packaged from the manufacturer under cover and secured with metal strapping (**FIG. A**). If possible, panels should remain in this original packing for transport.

If a forklift or pallet jack is unavailable, panel unit may be broken and carried to storage by hand according to the following guidelines.

### HANDLING THE MATERIAL:

A strippable protective film is standard on all panels. This film should remain on the product until instructed to take it off (during installation procedure). This strippable film (FIG. B) is designed to prevent minor abrasions to the surface. However, panels should still be handled with care to avoid any major dings, dents or scratches.

FIGURE B.

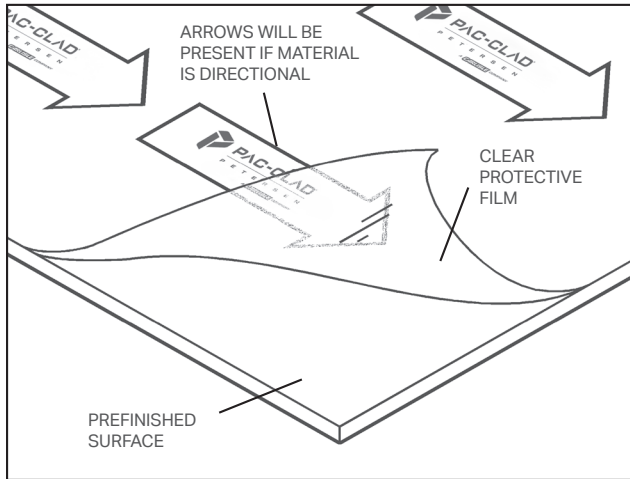

#### NOTE:

- When handling panels, clean work gloves should be worn at all times to protect from sharp edges and to prevent any smudging of the painted finish.
- When removing material from shipping units, DO NOT drag/slide panels across stack underneath. Panels must be lifted up, then away to avoid any permanent damage to the painted surface (FIG. C).

FIGURE C.

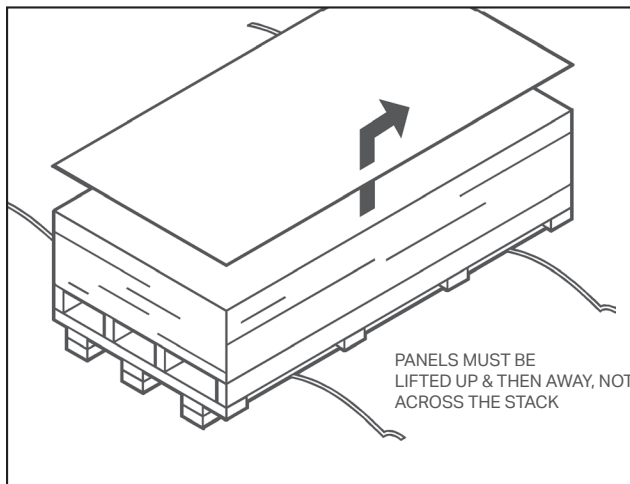

## PRE-FABRICATION: STORING THE MATERIAL UNITS

### MATERIAL STORAGE:

If the units have been broken, material should be restacked, on a skid. Painted surfaces (strippable film side) should face upward with the final panel flipped over to protect the finish.

#### NOTE:

**Failure to properly protect material from moisture intrusion may cause damage to the panel surface and/or core. Such damage is NOT covered under the standard warranty.**

If the material has become damp or wet during transportation, the surface should be wiped dry before stacking to prevent any type of corrosion. Once the stacking is completed (or if the original packaging is still intact), the units must be covered with a waterproof covering.

All units must be kept in a dry, well-ventilated area away from exposure to the elements and/or any other construction installations which may cause damage to the product.

# Section II:

## Fabrication Guidelines

### SAFETY PRECAUTIONS:

When performing fabrication procedures, it is necessary to observe all general guidelines for safety. Cutting, drilling, or otherwise machining the panels and attachment extrusions may produce flying chips, shavings or dust.

#### NOTE:

In addition to work gloves and proper clothing, safety goggles, ear protection, and possibly dust masks may be needed when fabricating system components.

### FABRICATION: CUTTING THE PANELS TO SIZE

#### TYPE OF EQUIPMENT:

In most cases, machinery types where the blade moves, rather than the panel, is preferred. However, panels may be cut to the correct dimension using various types of industrial/commercial equipment including;

- Table Saws
- Beam Saws
- Reciprocating Saws
- Panel Saws (vertical)
- Portable Circular Saws
- Multiple Operation Saws

Carbide tipped blades are recommended for all cutting and fabrication operations.

#### NOTE:

Due to the composition of the panel core, shearing and/or punching the material IS NOT recommended.

#### CARE OF THE PAINTED SURFACE:

Regardless of machinery type, care must always be taken to protect the painted surface from damage. The protective film is to remain on the panel until installation is complete.

When using portable saws (hand held circular or reciprocating), work surfaces should be padded and free from debris which may cause damage to the finish. For cleaner cuts, backer blocks and straightedges may be clamped to the panel surface (**FIG. D**). Caul blocks should be used when necessary.

FIGURE D.

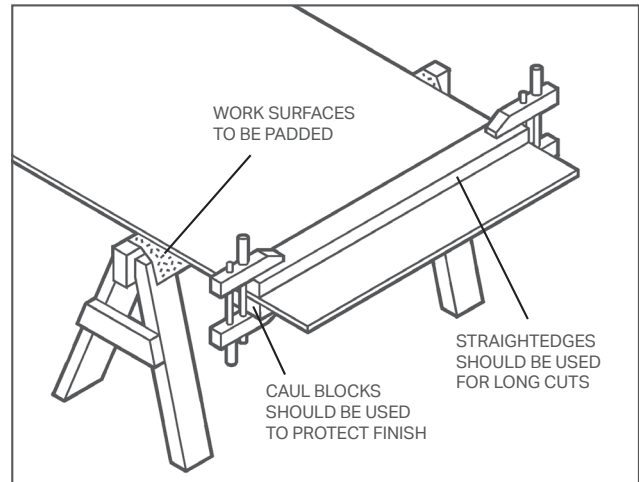

#### PANEL ORIENTATION:

The panel should always be oriented so that the cutting blade pulls into the aluminum on the prefinished side. For example, when using a table saw or beam saw to cut panels, the finished side (protective film) should be placed facing upward.

For hand held circular saws, vertical panel saws and jigsaws, the finish side should be facing down or away from the operator (**FIG. E**).

For drilling operations, the finished side should be placed facing upward and a backer block should be used when necessary to minimize any tearout.

FIGURE E.

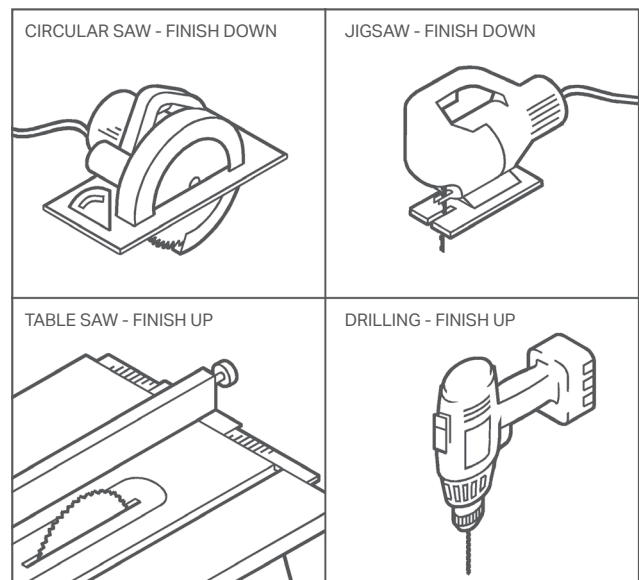

### CUTTING TO THE CORRECT DIMENSION:

When determining panel size, proper allowance should be made to accommodate the returned edges of the panel. Add 1-1/32" for each side (FIG. F) of the panel to the face dimension of the formed 'pan' (keep in mind that this dimension will differ from the grid dimension).

FIGURE F.

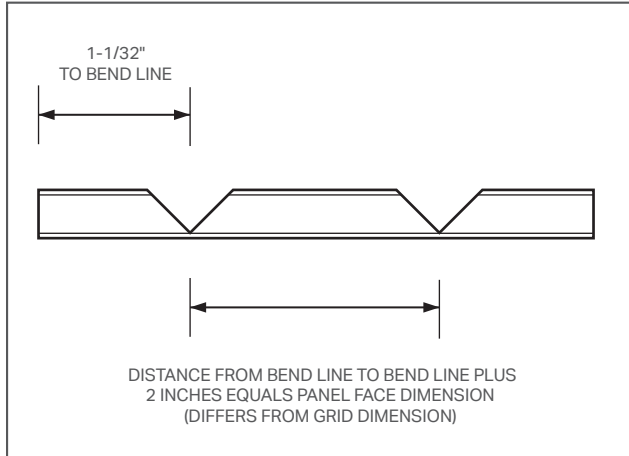

After cutting, aluminum edges may need filing (FIG. G) to remove sharp projections and/or metal burrs. Doing so will reduce the risk of personal injury.

FIGURE G.

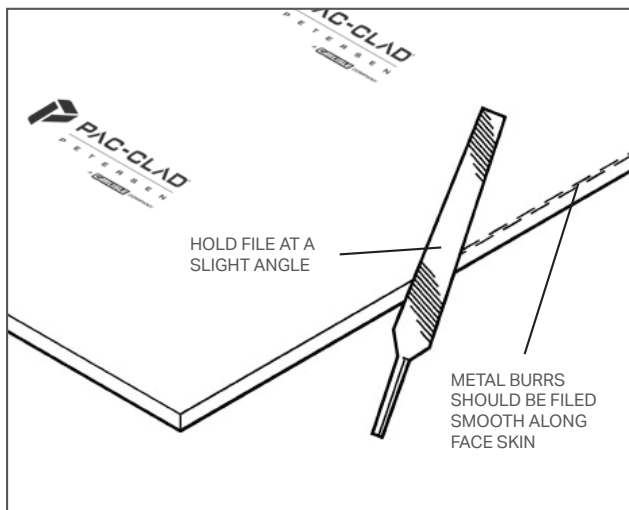

## FABRICATION: USING A PORTABLE ROUTER

### OVERVIEW:

When the Rout & Return (RR) System or the RainScreen (RS) attachment system has been specified, a returned edge must be formed along the perimeter of the panel. To make this type of edge (also found at inside/outside corner conditions), a 'V' shaped groove (FIG. H) must first be routed into the back side of the panel.

FIGURE H.

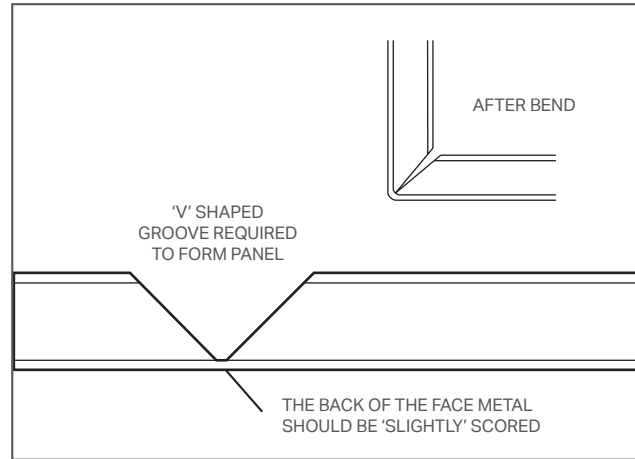

This can be accomplished using either a hand held router or a cutting table with a custom blade. Regardless of the method used, a crisp and consistent groove must be created in order to make the proper bend line.

Panels should be placed finish side down on a clean, rigid work surface to adequately support the panel and prevent bowing when pressure is applied.

### BIT SPECIFICATIONS:

For 90° bends, a carbide-tipped bit with a 1/2" shank and a 95°-105° angle is recommended (FIG. I). The tip of the router bit should be slightly rounded (approx. 5/64").

FIGURE I.

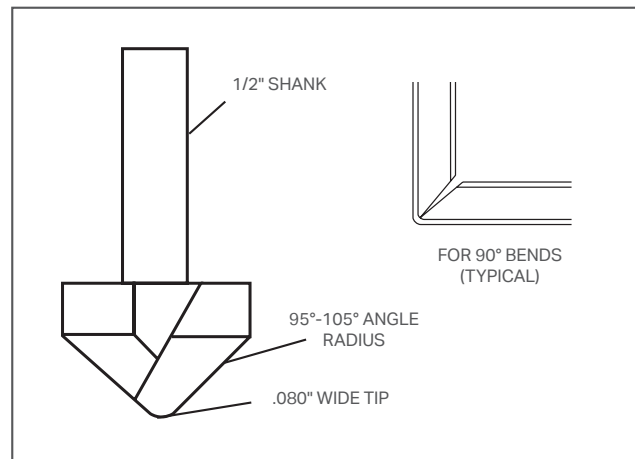

For 45° bends (as an option for inside and outside corner conditions) a separate router bit with a 120° angle is required (FIG. J) to remove an adequate amount of core material. As with the bit for 90° bends, the tip should be slightly rounded (approx. 5/64").

**FIGURE J.**

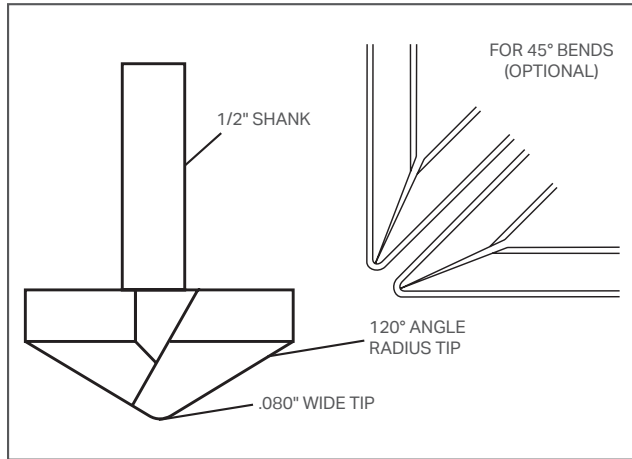

**MARKING THE BEND LINE:**

Indicate the pivot point of the bend with a chalk line marked across the panel.

**NOTE:**

For formed 'pan' edges, the bend line should be located 1-1/32" away from the panel edge.

Measure the distance from the center point of the router bit to the edge of the router base. Using that dimension, locate a straightedge parallel to the bend line (FIG. K). The straightedge should be firmly clamped on both ends to prevent movement during routing and should extend past the edge of the panel.

**FIGURE K.**

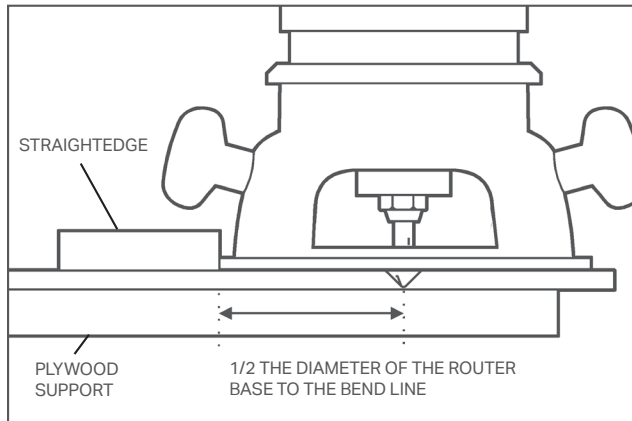

**SETTING THE CORRECT DEPTH:**

The correct routing depth can be determined using scrap pieces of panel. The bit should be set so that it completely removes the core material in the groove and slightly 'scores' the back of the face skin (FIG. L).

**FIGURE L.**

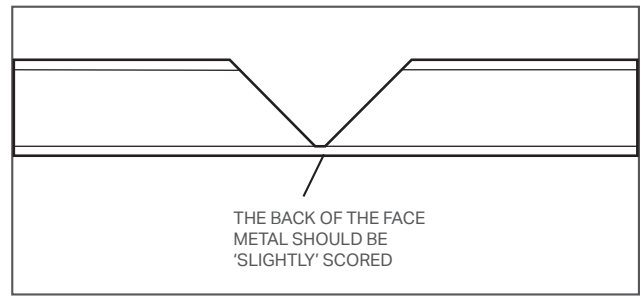

**ROUTING THE GROOVE:**

Once the guide has been properly clamped in place and the correct routing depth is set, the v-groove may be routed moving across the panel at a consistent speed and pressure (FIG. M). Consideration for the rotation of the bit should be made when determining which direction to move the router.

Once the groove has been routed, any remaining core material (due to the manufacturing tolerance in panel thickness) should be removed using a metal scraper.

**FIGURE M.**

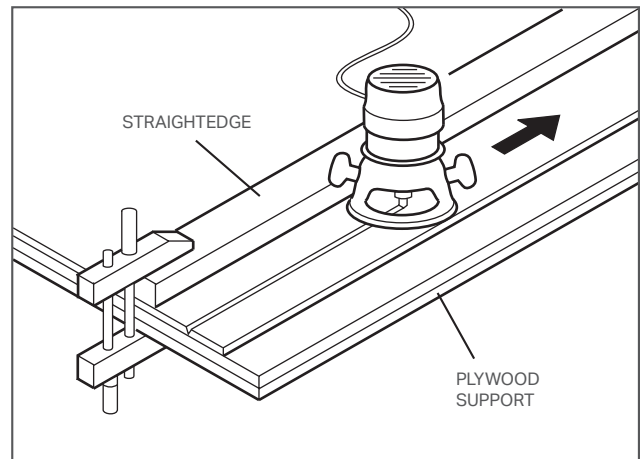

**FABRICATION: ROUTING WITH A TABLE AND BLADE**

**OVERVIEW:**

For more consistent routing or production runs, a table saw fitted with a custom routing (or 'V') blade is recommended (FIG. N). This type of blade, along with an industrial quality saw will produce the required groove much more efficiently than hand routing. Autofeed accessories can also be mounted to the table to assist in maintaining a consistent groove.

**FIGURE N.**

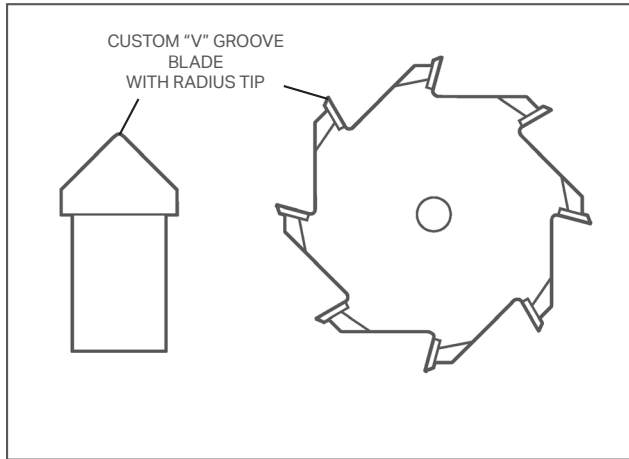

**FABRICATION:  
CURVING THE PANELS**

**TYPE OF MACHINERY:**

When the design calls for a curved panel (i.e. column covers, rounded corners, etc.), this can be accomplished using a variety of methods. Pyramid rollers, a clamped pipe/hinged table assembly, or press brake techniques may all be used to achieve the proper bend (depending upon radius requirement). Precautions should be taken at all times to protect the panel face from any debris that might cause damage to the painted finish.

The minimum recommended bending radius (**FIG. O**) for the panel is 12". Consult our technical staff if special conditions are required.

**FIGURE O.**

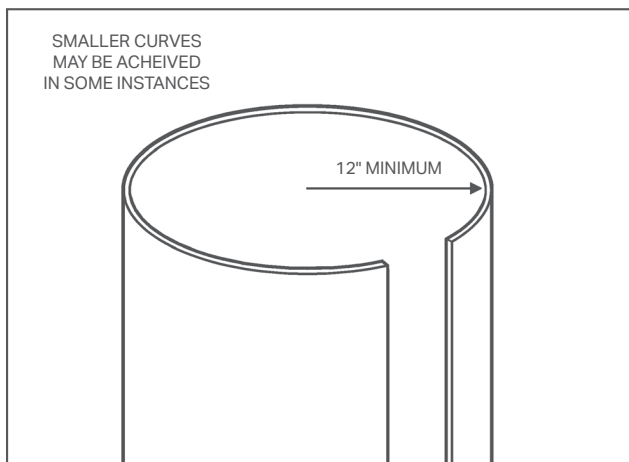

**NOTE:**

**ALL routing must be completed before the panels are to be curved.**

**PYRAMID ROLLER:**

When using a pyramid roller (**FIG. P**), it is best to create the curve in small increments (to prevent buckling). A small amount of springback may occur after the panel is curved. Therefore, it may be necessary to roll the panel slightly tighter than the desired finished radius.

**FIGURE P.**

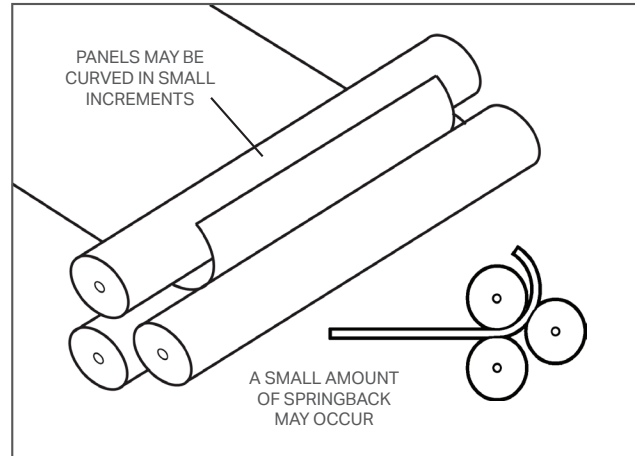

**CLAMPED PIPE/HINGED TABLE:**

Panels may also be bent to the correct radius by using a pipe (with the proper dimension or slightly smaller to accommodate springback) clamped to a stationary work table (**FIG. Q**). Raising the hinged section will bend the panel to the shape of the pipe (or die).

**FIGURE Q.**

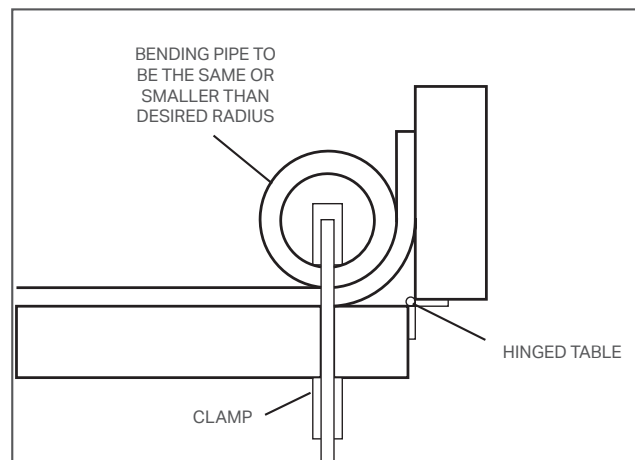

**PRESS BRAKE:**

Bending the panel using press brake techniques requires that a protective material (i.e. rubber, etc.) be placed between the panel and the die (on both sides).

The top die is lowered into the panel (**FIG. R**) and the proper curve is created by the radius of the tubing. The lower jaws should be slightly further apart than the width of the top die to allow for the panel to bend.

**FIGURE R.**

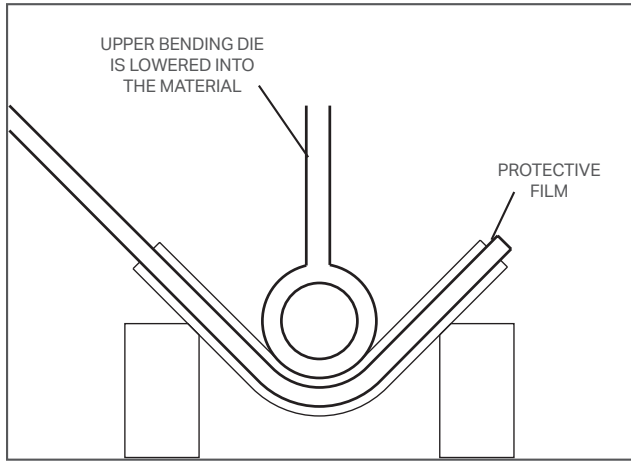

**FABRICATION:  
RETURNING THE PANEL EDGE**

**NOTCHING THE CORNERS:**

Before bending the panel edge, the corner tab must be removed to create the space needed for the adjacent flanges to come together. Either a square corner or a pyramid section (**FIG. S**) must be removed (using a reciprocating saw), depending upon preference.

**BENDING THE PANEL:**

In general, large sections of panel may be bent to the desired angle by hand. However, for short flanges, a simple tool (fabricated on site) may be required to gain the grip/leverage needed to return the edge (**FIG. T**). Long stretches of panel are to be bent in small increments moving along the length of the routed groove.

To minimize the cracking which may occur at the bend line, a heat gun may be used to slightly 'warm' the face

**FIGURE T.**

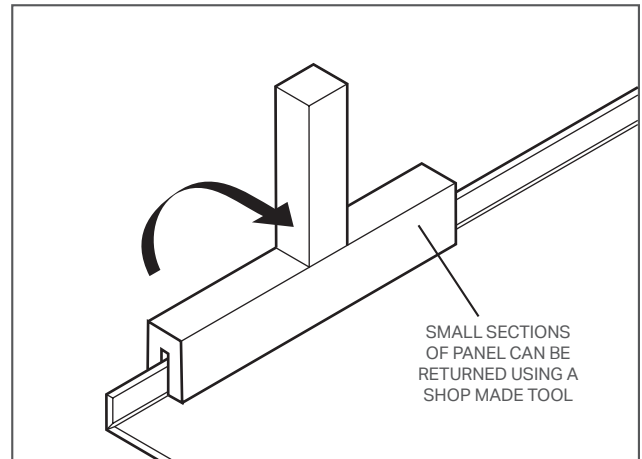

**FIGURE S.**

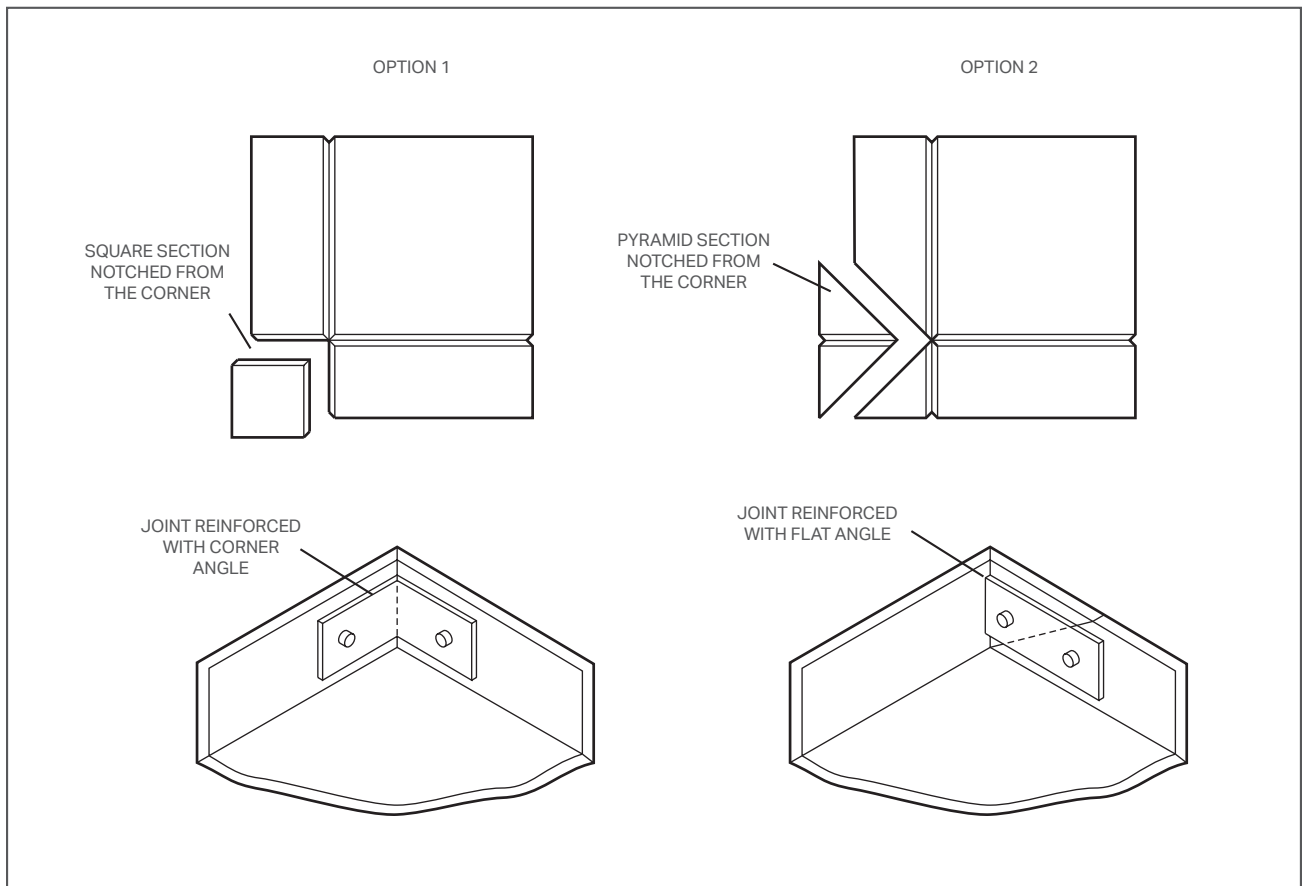

sheet. It is also recommended that bending be performed when the air temperature is at or above 70° for best results.

To create an inside or outside corner, the same v-groove is required to remove the necessary material and the same bending directions apply (**FIG. U**).

**FIGURE U.**

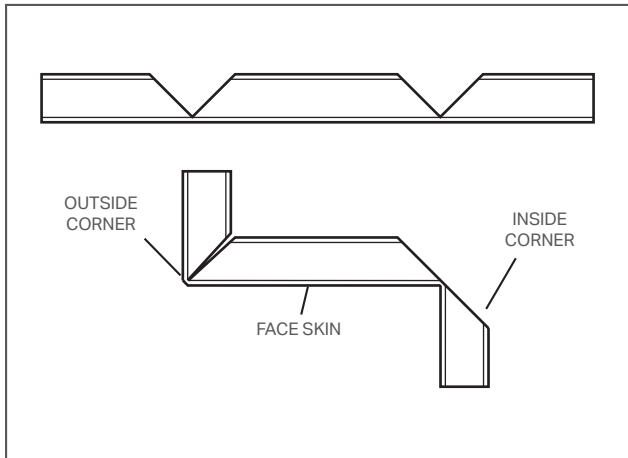

**NOTE:**

Once the panel edge has been returned, **DO NOT FLATTEN OR REBEND**. Doing so will weaken the metal and may cause failure in the aluminum skin.

**FABRICATION:  
EDGE RETURNS FOR CURVED PANELS**

**NOTCHING THE PANEL SIDES:**

After the routing has taken place and before the panel is to be curved, relief cuts (or notches) must be made into the side legs of the panel (**FIG. V**). Doing so will allow the panel to achieve the desired radius while still maintaining the formed 'pan'. The shape and size (as well as the frequency) of the relief cut (or notch) will be dependent upon the size of the radius to be achieved.

**NOTE:**

Relief cuts or 'notches' must be made in the panel edge prior to curving.

**FIGURE V.**

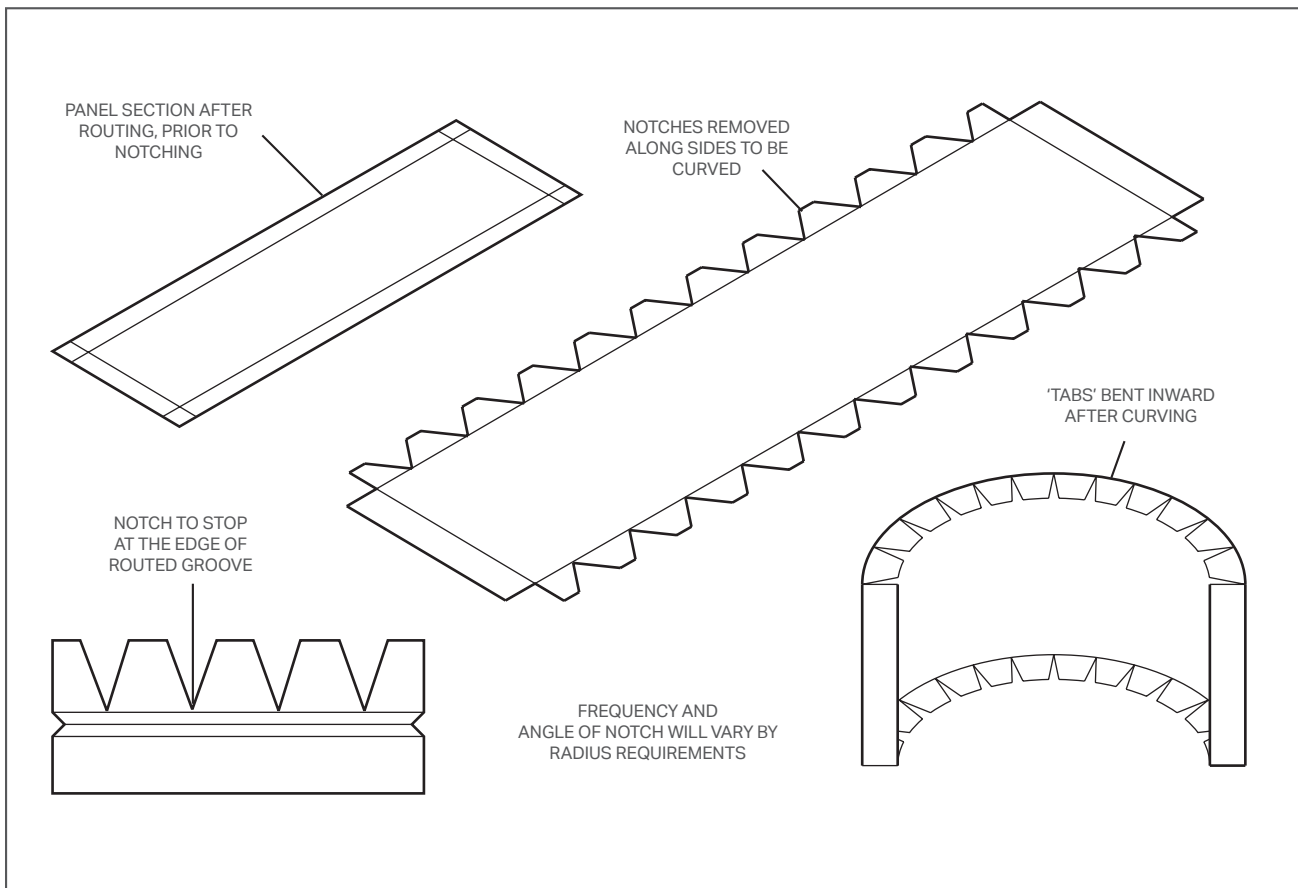



# Section III:

## Panel Assembly

### BEGINNING THE ASSEMBLY:

Once the panels have been cut-to-size and any necessary routing/bending has been performed, assembly can begin. There are several different attachment extrusions and aluminum angles that may be used depending upon specific job requirements and type of system selected. Be sure to verify the type of attachment that has been specified.

### ASSEMBLY: CORNER REINFORCEMENTS

#### WITHIN THE 'PAN' CORNERS:

If the Rout & Return (RR) attachment system has been specified, the RR-103 corner reinforcements will be placed in the corners prior to the perimeter mounting extrusions. However, for the RainScreen (RS) attachment system, the perimeter extrusions are put into place before the corner reinforcement angles.

Once the panel edge has been returned into position, the four corners of the 'pan' are to be reinforced using small aluminum brackets set in a bed of sealant (**FIG. W**). Pilot holes are to be drilled into the panel edge and through the bracket. Then the angle is secured using one, 3/16" pop rivet per leg.

FIGURE W.

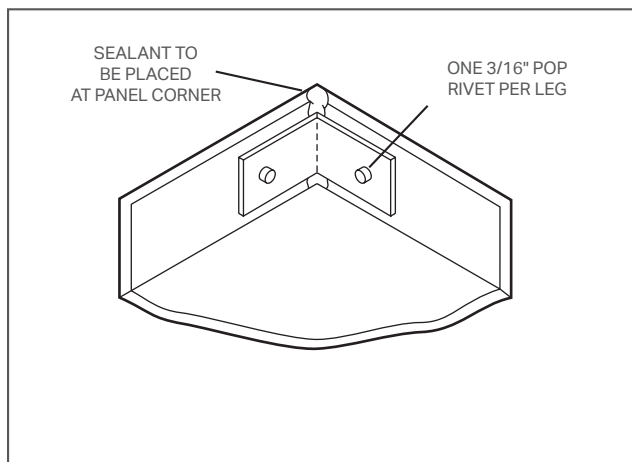

#### REINFORCING A 90° BEND:

Once the panel has been properly prepared (this will be dependent upon which system is specified) and the panel has been bent into position, pilot holes should be drilled through the returned edge and the aluminum angle. Attach the angle using two, 3/16" pop rivets spaced a minimum of 1" apart (**FIG. X**).

FIGURE X.

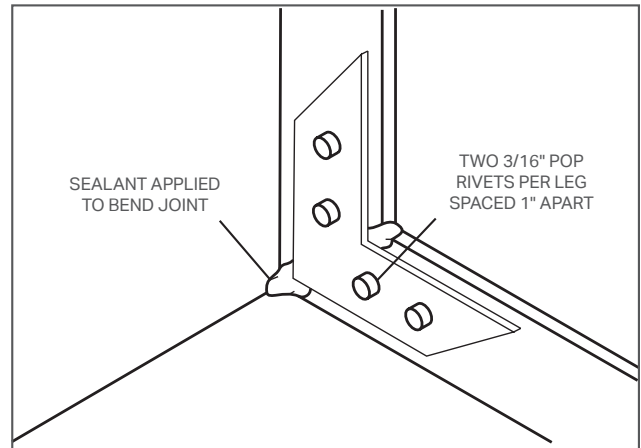

### ASSEMBLY: ROUT & RETURN (RR) SYSTEM

#### ABOUT THE PERIMETER EXTRUSIONS:

The Rout & Return (RR) system is designed so that once installed, each panel will be mechanically fastened on at least two sides (using either the RR-104 End Run Angle or the RR-121 Male Angle) with the remainder of the sides 'floating' in an extrusion mounted to the back of the adjoining panel (RR-122 Female Angle).

This 'inter-connection' (**FIG. Y**) of the panels allows for movement within the wall system to allow for expansion/contraction. The position of the panel within the elevation will determine the number of mechanically fastened sides and the number of 'floating' sides.

FIGURE Y.

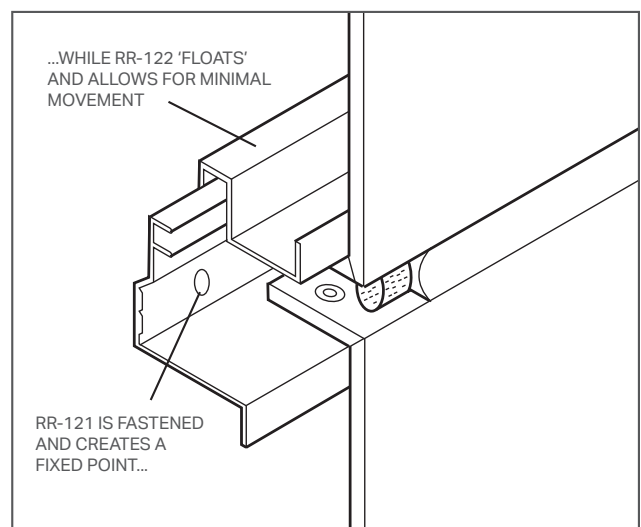

**FIGURE Z.**

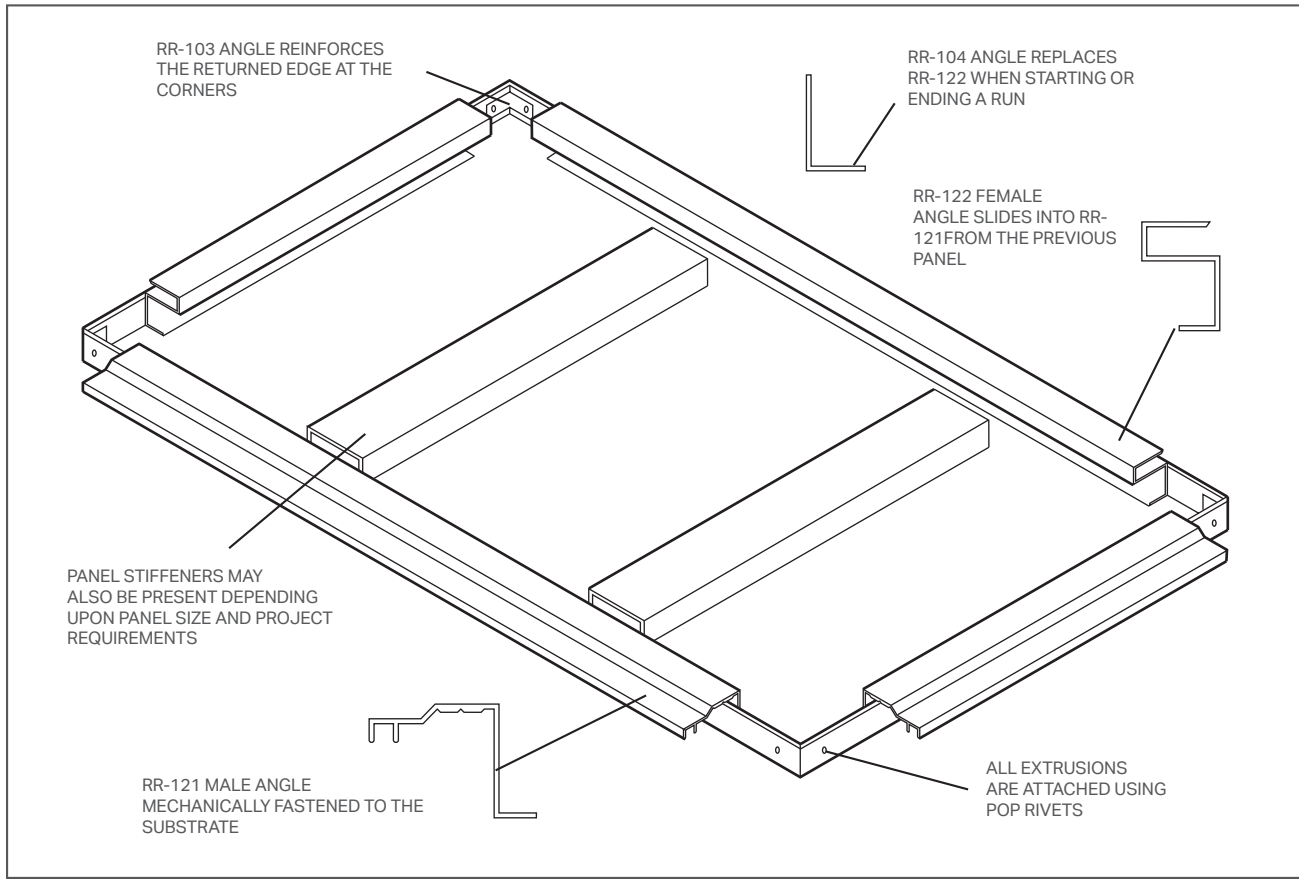

**NOTE:**

Be sure to consult the shop drawings to determine the proper location of the extrusions (FIG Z).

aluminum extrusion to the returned edge using two 3/16" pop rivets, located at the centerline of the panel, 1" to 2" apart (FIG AA).

Two more sets of rivets should be placed approximately 1" to 3" from each end. Along the length of the extrusion, rivets should be placed at every 16" o.c..

**ATTACHING THE EXTRUSIONS:**

Once the corners have been reinforced, the perimeter extrusion may be mounted to the panel. Attach the

**ASSEMBLY:  
RAINSCREEN (RS) SYSTEM**

**FIGURE AA.**

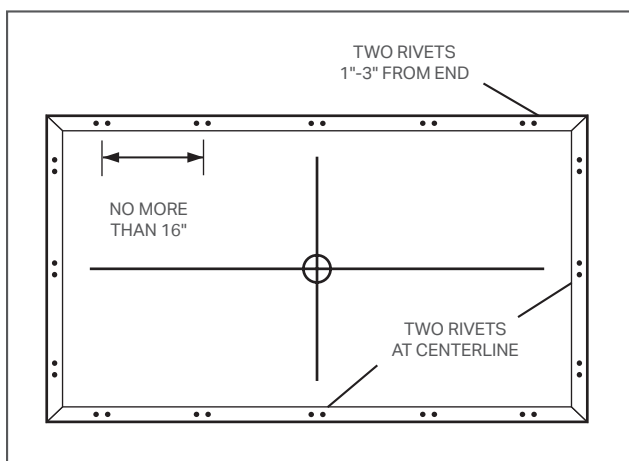

**ABOUT THE PERIMETER EXTRUSIONS:**

The RainScreen (RS) attachment system is designed so that once installed, each panel will be mechanically fastened to the substrate on at least two sides, using 6" sections of the 8214 extrusion attached to the 8216 extrusion on the back of the panel (FIG. BB), with the remainder of the sides 'floating' in an extrusion mounted to the substrate (8212 extrusion).

This 'inter-connection' of the panels allows for movement within the wall system to allow for expansion/contraction. The position of the panel within the elevation will determine the number of mechanically fastened sides and the number of 'floating' sides.

**FIGURE BB.**

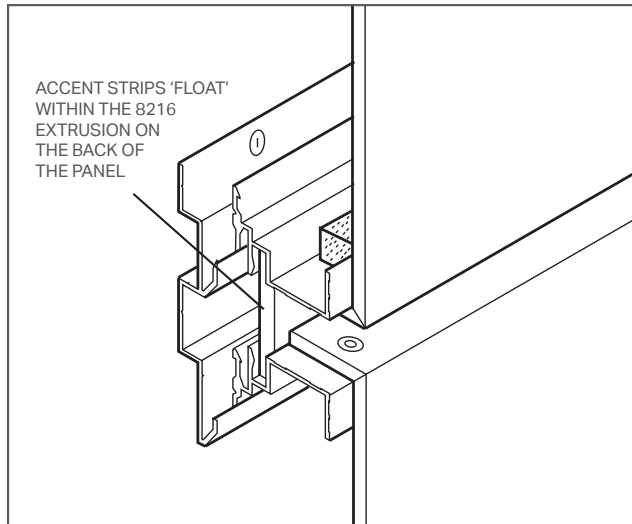

**NOTE:**

Be sure to consult the shop drawings to determine the proper location of the extrusions (FIG CC).

**ATTACHING THE EXTRUSIONS:**

Before attaching the perimeter extrusions, each section must be properly mitered so that once installed on the back of the panel, the extrusion is continuous. Attach each length to the returned edge using two 3/16" pop rivets, located at the centerline of the panel, 1" to 2" apart (FIG DD). Two more sets should be placed 1" to 3" from each end. Along the length, rivets are placed 16" o.c..

**FIGURE DD.**

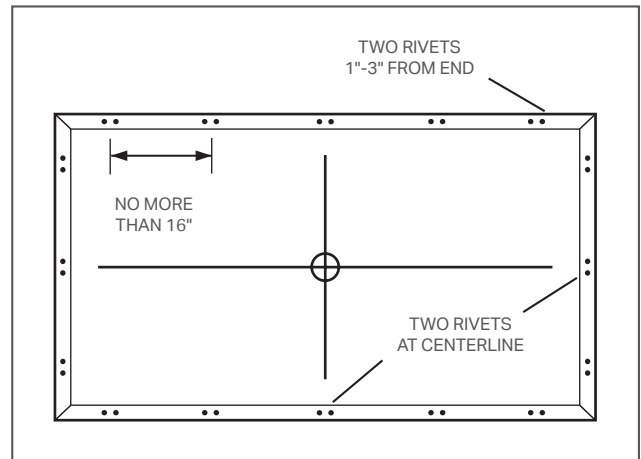

**FIGURE CC.**

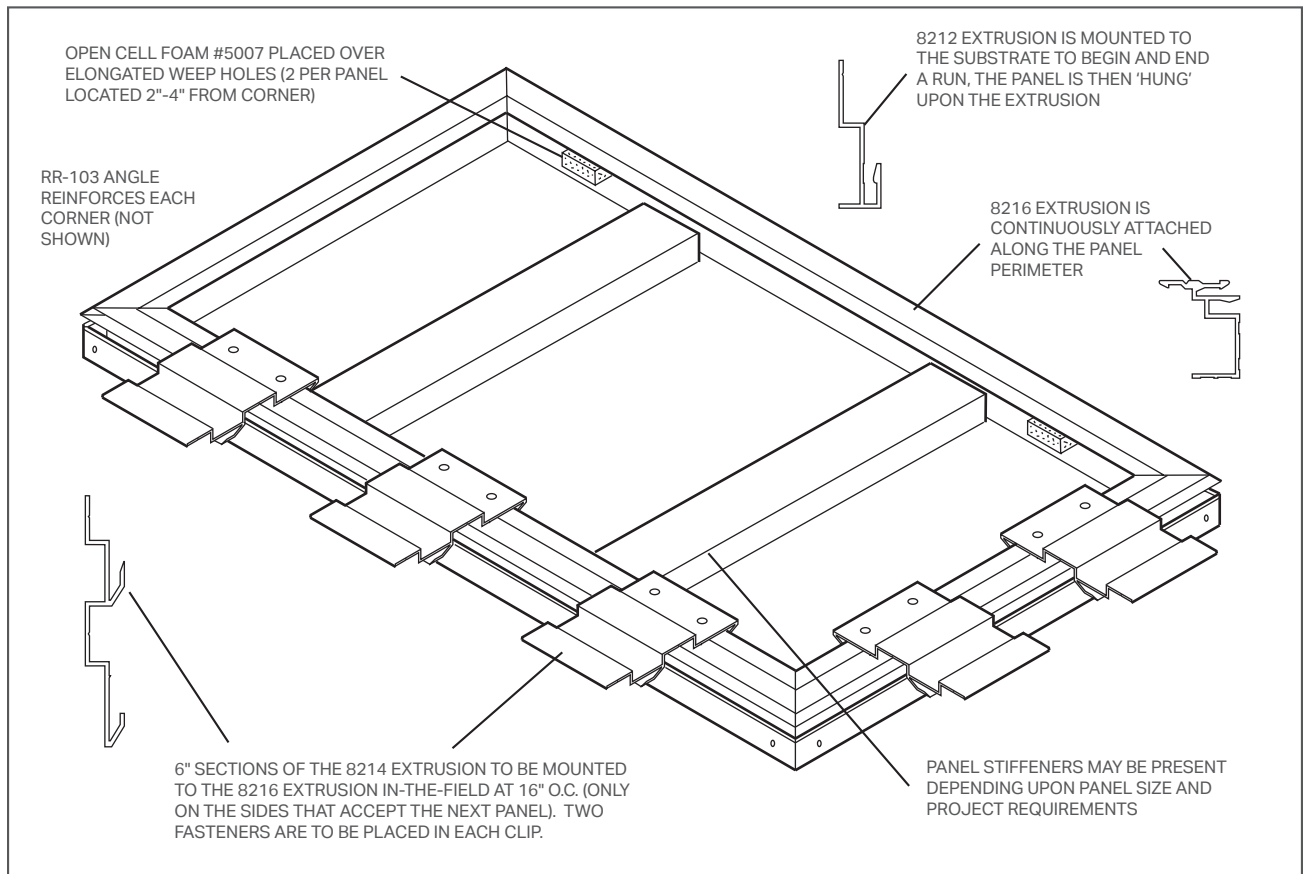

**NOTE:**

Pop rivets must be counterunk flush (FIG. EE) with the outside aluminum skin of the panel (RS Attachment System only).

**FIGURE EE.**

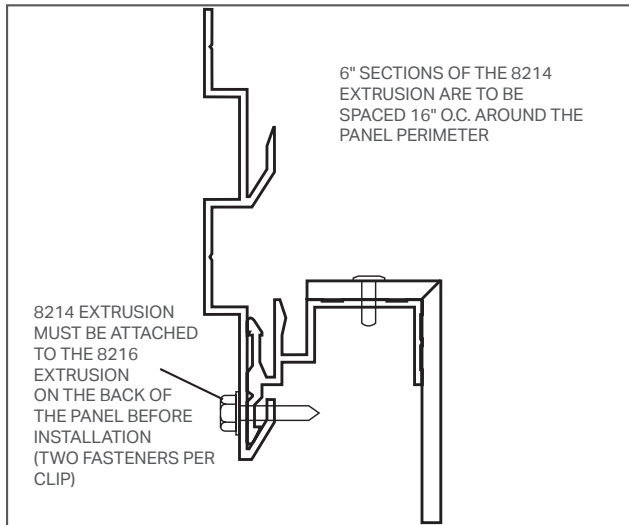

**WEEP HOLES:**

After the placement of the perimeter extrusion, weep holes must be drilled/routed into what will become the bottom edge of the panel (once the panel is installed). The hole should pass completely through the returned edge and the aluminum extrusion and must be elongated to 1/4" x 3/4". Two holes are to be placed on each panel, 2"-4" from the corner (FIG. FF).

Once the holes are complete, a small section of the weep baffle is to be placed on the inside of the pan and over the hole. The baffle may be held into position using small daubs of sealant (making sure not to cover the hole).

**FIGURE FF.**

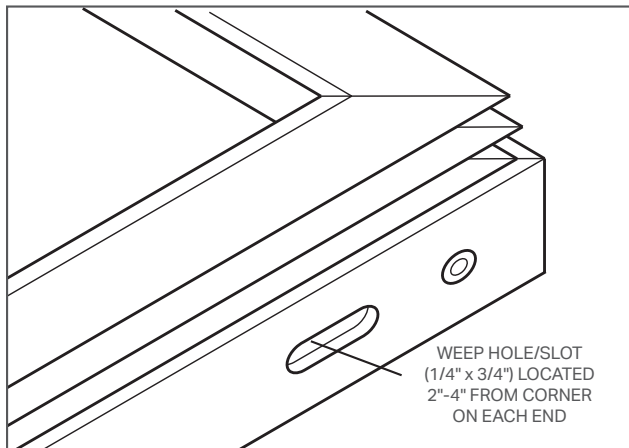

**ASSEMBLY:  
PANEL STIFFENERS**

**ATTACHING THE EXTRUSION:**

Depending upon the grid size (and/or project conditions), stiffeners may be required as part of the panel assembly. The aluminum extrusion is designed to reduce panel deflection and aid in resisting wind loads.

Stiffeners are to be cut to the proper length (to fit within perimeter extrusions) and applied using a strip of double sided tape down the center, followed by two beads of sealant along the edges (FIG. GG). One stiffener is to be placed at the centerline of the panel, with others (if necessary) placed approximately 24" o.c. apart, across the short side of the panel.

**NOTE:**

Once the stiffeners are put into position, **DO NOT** move the panel for a 24 hour period.

**FIGURE GG.**

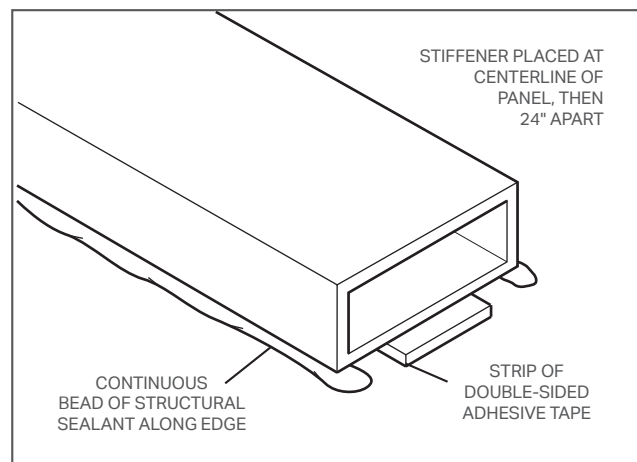

# Section IV:

## Attachment Extrusions

### ROUT & RETURN (RR) ATTACHMENT EXTRUSIONS

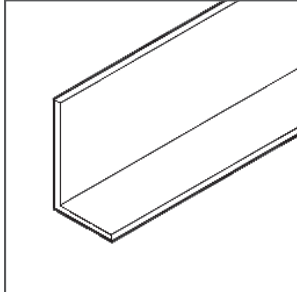

#### RR-104 END RUN ANGLE

Height: 1-1/4" (32mm)  
 Width: 3/4" (19mm)  
 Length: 12'-6" (3810mm)

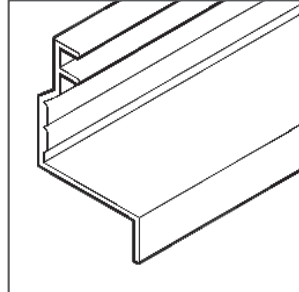

#### RR-121 MALE ANGLE

Height: 2" (51mm)  
 Width: 1-3/8" (35mm)  
 Length: 12'-6" (3810mm)

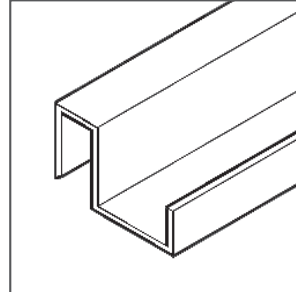

#### RR-122 FEMALE ANGLE

Height: 7/8" (22mm)  
 Width: 1-3/8" (35mm)  
 Length: 12'-6" (3810mm)

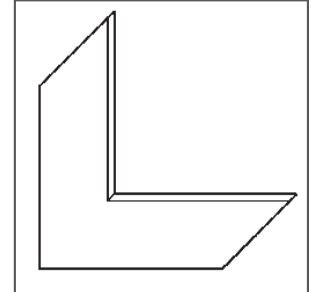

#### PF-204 REINFORCEMENT

Height: 2" (51mm)  
 Leg Width: 3/4" (19mm)  
 Length: n/a

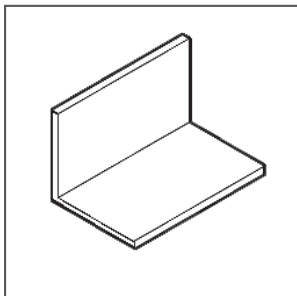

#### RR-103 PANEL CLIP

Height: 1-1/2" (38mm)  
 Width: 1" (25mm)  
 Length: 12'-6" (3810mm)

Note: Angle cut to smaller peices (shown) for use on formed panels.

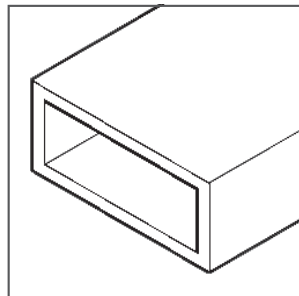

#### STIFFENER TUBE

Height: 1" (25mm)  
 Width: 2" (51mm)  
 Length: 12'-6" (3810mm)

## RAINSCREEN (RS) ATTACHMENT EXTRUSIONS

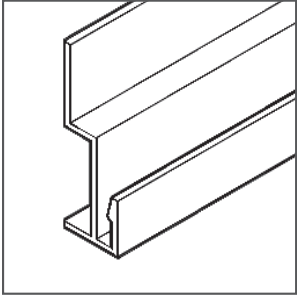

### 8212 EXTRUSION

Height: 2-1/8" (54mm)  
 Width: 1/2" (13mm)  
 Length: 12'-6" (3810mm)

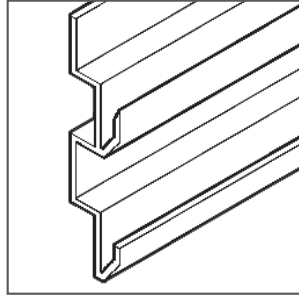

### 8214 EXTRUSION

Height: 3-1/2" (89mm)  
 Width: 1/2" (13mm)  
 Length: 12'-6" (3810mm)

Note: Angle cut to 6" sections for use on formed panels.

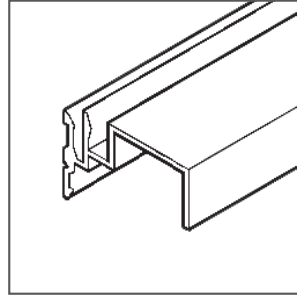

### 8216 EXTRUSION

Height: 1-1/8" (29mm)  
 Width: 1-3/8" (35mm)  
 Length: 12'-6" (3810mm)

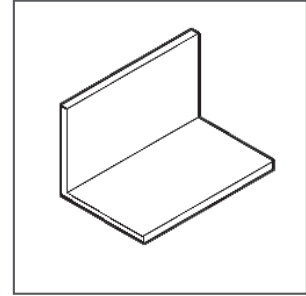

### RR-103 PANEL CLIP

Height: 1-1/2" (38mm)  
 Width: 1" (25mm)  
 Length: 12'-6" (3810mm)

Note: Angle cut to smaller peices (shown) for use on formed panels.

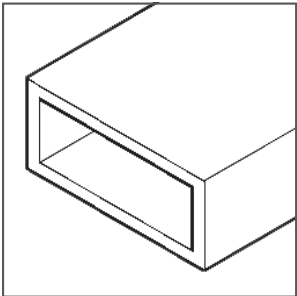

### STIFFENER TUBE

Height: 1" (25mm)  
 Width: 2" (51mm)  
 Length: 12'-6" (3810mm)

# Section V:

## Technical Data

### MATERIAL TOLERANCES:

Thickness:  $\pm 1/32"$  ( $\pm 0.79\text{mm}$ )  
 Length Dim:  $+0, -1/16"$  ( $+0, -1.59\text{mm}$ )  
 Width Dim:  $+0, -1/16"$  ( $+0, -1.59\text{mm}$ )  
 Squareness:  $1/64"$  ( $0.4\text{mm}$ ) per lineal foot

PAC-4000 is supplied with clean, machine trimmed edges.

### SIZES AVAILABLE:

48" x 96" (1219mm x 2438mm)  
 48" x 120" (1219mm x 3048mm)  
 48" x 144" (1219mm x 3658mm)  
 60" x 96" (1524mm x 2438mm)  
 60" x 120" (1524mm x 3048mm)  
 60" x 144" (1524mm x 3658mm)

Cut-to-size panels are also available in virtually any size up to 60" x 144."

### CODE CERTIFICATION<sup>1</sup>:

BOCA (Building Officials Code Administrators) - #21 • 08\*

\*Compliance with 1999 National Building Code

ICC-ES (International Code Council Evaluation Service) - # ESR-1015

Compliance with 2000 International Building Code<sup>2</sup>, 1997 Uniform Building Code<sup>TM</sup>

<sup>1</sup> PAC-4000 RR attachment system.

### STANDARD WARRANTY:

Panel Warranty: 10 Years  
 Kynar 500<sup>®</sup> Finish: 20 Years  
 No change greater than 8 for chalk, 5 E units for fade  
 Anodized Finish: 20 Years (prorated)

### PANEL FINISH SYSTEMS:

Standard Smooth: Coil Coated  
 Kynar 500  
 Custom Smooth: Spray Applied  
 Kynar 500

**TABLE 1. COMPOSITION & MATERIALS<sup>1</sup>:**

| COMPONENT                                    | STANDARD (IN) | METRIC (MM) |
|--|---------------|-------------|
| • Prefinished Smooth Aluminum Face           | .024" (min)   | .609mm      |
| • Thermoset Phenolic Resin Core <sup>2</sup> | .105"         | 2.67mm      |
| • Primed Smooth Aluminum Backer              | .010"         | .254mm      |

**TABLE 2. PANEL WEIGHT & THICKNESS:**

| COMPONENT                 | STANDARD                 | METRIC                 |
|---------------------------|--------------------------|------------------------|
| Panel Weight <sup>3</sup> | 1.33 lbs/ft <sup>2</sup> | 6.47 kg/m <sup>2</sup> |
| Nominal Thickness         | 1/8"                     | 4mm                    |

**TABLE 3. PANEL PERFORMANCE<sup>1</sup>:**

| PROPERTY                                      | TEST       | VALUE               | UNIT                         |
|---|------------|---------------------|------------------------------|
| R-Value                                       | ---        | 0.05                | °F ft <sup>2</sup> /BTU      |
| Flame Spread                                  | ASTM E84   | Class A             | ---                          |
| Peel Strength                                 | ASTM D1781 | 34.5                | lb-in/lb                     |
| Stiffness (EI)                                | ASTM C393  | 1.14 <sup>E+3</sup> | lb-in <sup>2</sup> /ft width |
| Allowable Bending Moment                      | ASTM E72   | 1.82 <sup>E+1</sup> | lb-ft/ft width               |
| Tensile Yield Load                            | ASTM E72   | 7.34 <sup>E+3</sup> | lb/ft width                  |
| Ultimate Tensile Stress                       | ASTM D638  | 2.60 <sup>E+4</sup> | psi                          |
| Coefficient Of Thermal Expansion <sup>4</sup> | ASTM D1237 | 1.11 <sup>E-5</sup> | in/in/°F                     |
| Ignition Temperature                          | ASTM D1929 | 900                 | °F                           |

<sup>1</sup> Technical properties are based upon the typical composition. Selecting optional components may alter properties.

<sup>2</sup> 4mm is the most common thickness for PAC-4000. 3mm and 6mm are also available.

<sup>3</sup> Weight and testing based upon panels using an .024" smooth face and an .010" smooth back.

<sup>4</sup> See back for Thermal Expansion & Contraction calculations.

## THERMAL EXPANSION & CONTRACTION

### ALLOWANCE FOR MOVEMENT:

Within the system design, allowance should always be made for expansion & contraction of the PAC-4000 material. This is done by taking into account differences between shop/fabrication temperature and/or installed temperature, and potential material temperature.

The PAC-4000 panel can be expected to expand/contract 5/32" (0.156") in 10 feet with a 120°F temperature change.

To calculate thermal expansion/contraction, use the following equations:

$$\text{Expansion/Contraction} = C_{oe} \times L(\text{in}) \times \Delta T(^{\circ}\text{F})$$

$$C_{oe} = \text{Coefficient Of Thermal Expansion} = 1.11 \times 10^{-5} (0.0000111)$$

L(in) = long span of PAC-4000 panel

$\Delta T(^{\circ}\text{F}) = T_m - T_i$  where  $T_m$  is potential material temperature and  $T_i$  is the temperature when the material was fabricated or installed. A positive  $\Delta T$  indicates expansion and a negative  $\Delta T$  indicates contraction.

**TABLE 4. EXPANSION/CONTRACTION AT VARIOUS  $\Delta T$ :**

| L(IN) | $\Delta T(^{\circ}\text{F})$ |       |       |       |       |       |       |
|-------|------------------------------|-------|-------|-------|-------|-------|-------|
|       | 60                           | 80    | 100   | 120   | 140   | 160   | 180   |
| 48    | 0.032                        | 0.043 | 0.053 | 0.064 | 0.075 | 0.085 | 0.096 |
| 72    | 0.048                        | 0.064 | 0.080 | 0.096 | 0.112 | 0.128 | 0.144 |
| 96    | 0.064                        | 0.085 | 0.107 | 0.128 | 0.149 | 0.170 | 0.192 |
| 120   | 0.080                        | 0.107 | 0.133 | 0.160 | 0.186 | 0.213 | 0.240 |
| 144   | 0.096                        | 0.128 | 0.160 | 0.192 | 0.224 | 0.256 | 0.288 |



# LOAD DEFLECTION

## WINDLOAD CHART: PAC-4000 (4MM)

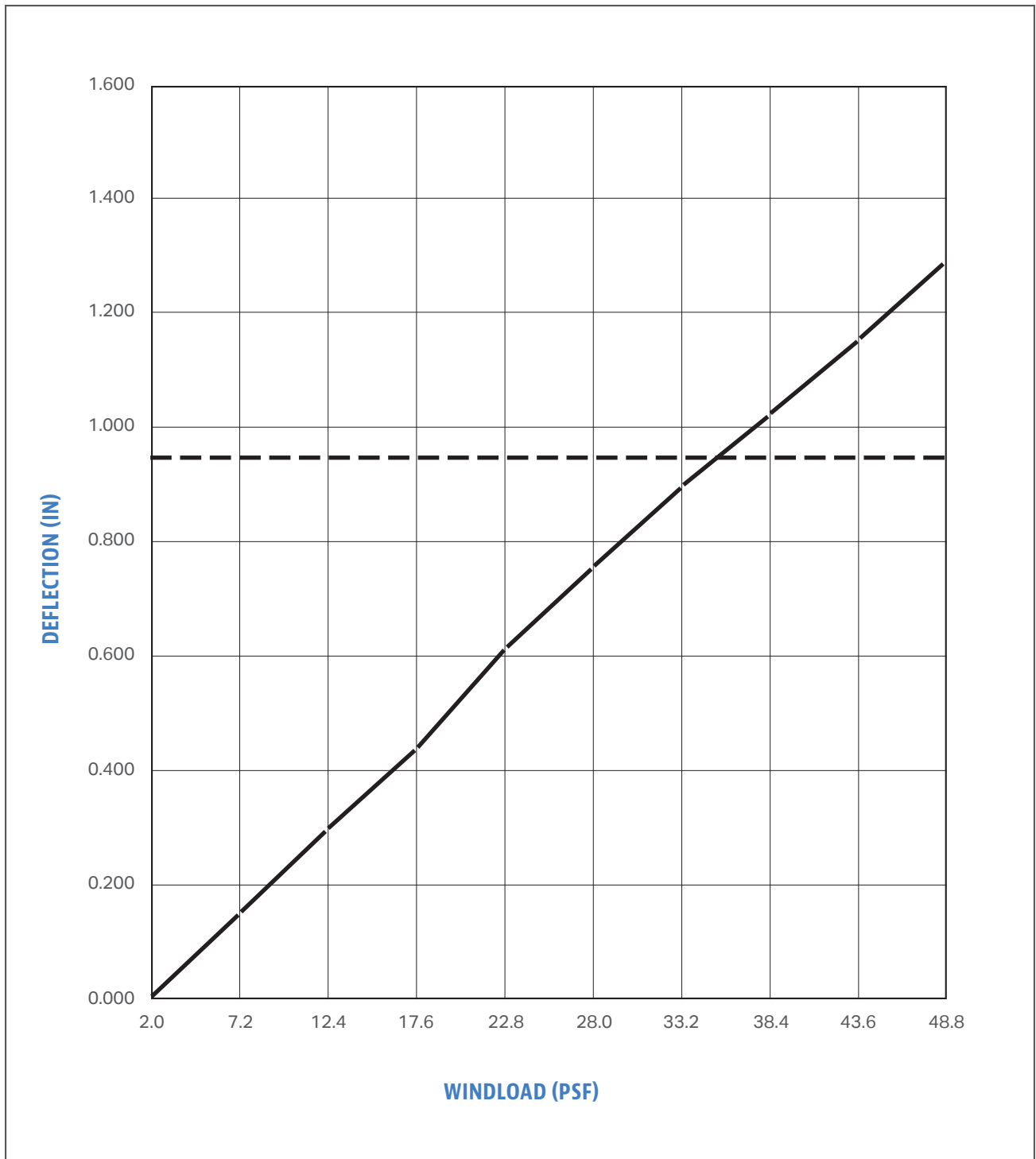

- 58" x142" PAC-4000 panel with stiffeners located 24" o.c.
- - - L/60 Deflection

# Section VI:

## Material Sources

### TWO-PART ADHESIVES

National Starch & Chemical Corp.  
Finderne Avenue  
Bridgewater, NJ 08807  
(908) 685-5000

Dymax Corporation  
51 Greenwoods Road  
Torrington, CT 06790  
(203) 482-1010

### CONSTRUCTION ADHESIVES

(supplied by Citadel)

### STRUCTURAL SEALANT

Dow Corning Corporation  
Product Information  
P.O. Box 997  
Midland, MI 48686  
(517) 496-6000

GE Silicon Products  
260 Hudson River Road  
Waterford, NY 12188  
(800) 332-3390

Tremco Corporation  
3735 Green Road  
Beachwood, OH 44122  
(216) 292-5000

### EPOXY

Lord Corporation  
Industrial Adhesives Department  
2000 West Grandview Boulevard  
Erie, PA 16514  
(814) 868-3611

Essex Specialty Products, Inc.  
1250 Harmon Road  
Aurbin Hills, MI 48326  
(810) 391-6300

### ROUTING BLADES

Drake Corporation  
1913 North Van Buren Street  
Huntingburg, IN 47542  
(812) 683-2101

### ATTACHMENT EXTRUSIONS

(supplied by Citadel)

### MECHANICAL FASTENERS

Pro-Fastening  
8126 Zionsville Road  
Indianapolis, IN 46268  
(800) 292-7550

### COATINGS & PAINTS

AKZO Nobel  
6369 Old Peachtree Road  
Norcross, GA 30071  
(770) 662-8464

Benjamin Moore & Company  
2501 West North Avenue  
Melrose Park, IL 60160  
(708) 343-3100

PPG Coatings  
One PPG Place  
Pittsburgh, PA 15272  
(412) 434-3131

Valspar Industrial Coatings  
701 South Shiloh Road  
Garland, TX 75042  
(972) 276-5191

Sherwin Williams  
10 Midland Building  
101 Prospect Avenue  
Cleveland, OH 44115  
(800) 331-7979

### SEALANTS

Dow Corning Corporation  
Product Information  
P.O. Box 997  
Midland, MI 48686  
(517) 496-6000

GE Silicon Products  
260 Hudson River Road  
Waterford, NY 12188  
(800) 332-3390

Tremco Corporation  
3735 Green Road  
Beachwood, OH 44122  
(216) 292-5000

### ADHESIVE TAPES

3M  
Industrial Tape and Specialties  
Division  
3M Center Building 220-7E-01  
St. Paul, MN 55144  
(800) 362-3550

Avery Dennison  
Specialty Tape Division  
250 Chester Street  
Painesville, OH 44077  
(216) 639-2600

Mactac  
Technical Products Division  
4560 Darrow Road  
Stow, OH 44224  
(800) 323-3439

Norton  
Norton Performance Plastics  
Corporation  
One Sealants Park  
Granville, NY 12832  
(800) 724-0883



