

19A OUTSIDE CORNER OPTION 1

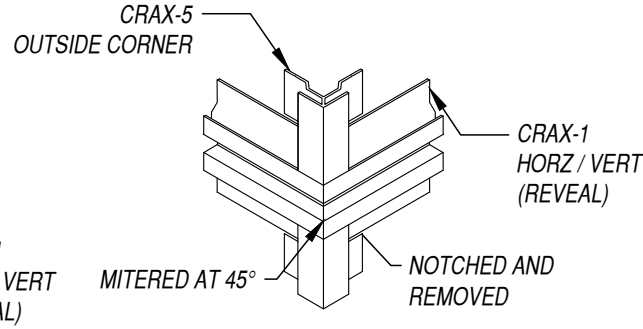

19C OUTSIDE CORNER OPTION 3

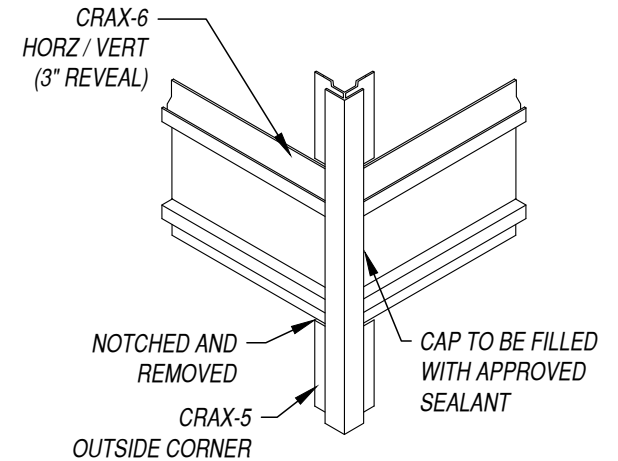

19E OUTSIDE CORNER OPTION 5

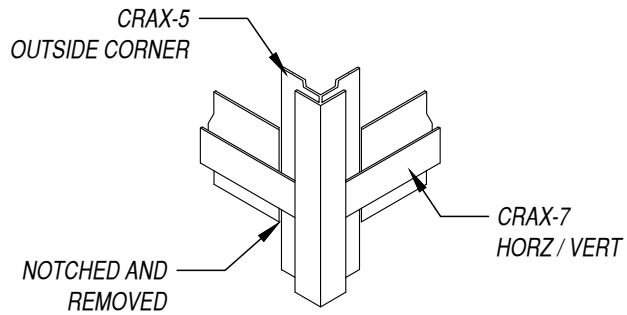

19B OUTSIDE CORNER OPTION 2

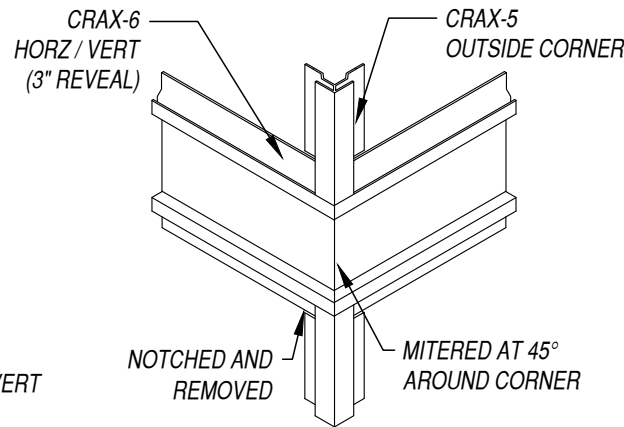

19D OUTSIDE CORNER OPTION 4

SCALE: N.T.S.
SUBJECT TO CHANGE WITHOUT NOTICE

DISCLAIMER: DETAIL SHOWN FOR ILLUSTRATION PURPOSES ONLY. ACTUAL PROJECT DETAIL MAY VARY