

# PAC-150 90° SEAM

## MATERIALS

.032 aluminum      24 gauge steel

## SPECS

12", 16", 18"  
or 20" O.C.\*      1-1/2" High

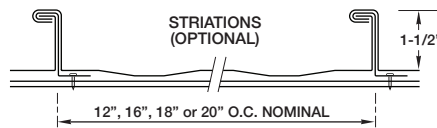
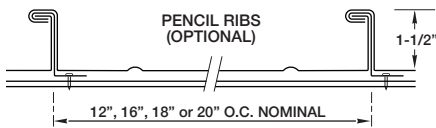
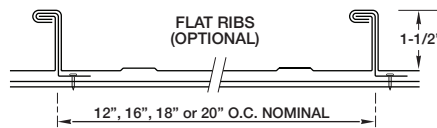
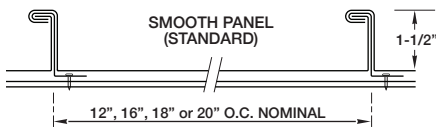
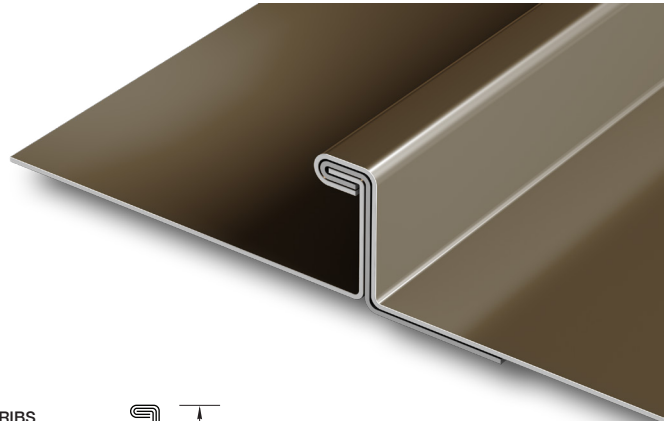

## PRODUCT FEATURES

- ▶ 35-year non-prorated finish warranty
- ▶ Weathertightness warranty available
- ▶ Available in four pan variations; smooth, striated, pencil rib or flat rib. Check locally for panel condition availability
- ▶ Maximum panel length of 64' when factory or shop-formed but virtually unlimited when field-formed

- ▶ Mechanically seamed in the field to 90°
- ▶ NOTE: Seamers for PAC-150 are not available from Petersen

## MATERIAL

- ▶ 24 gauge steel
- ▶ .032 aluminum
- ▶ Galvalume Plus available

## UL CLASSIFICATION

- ▶ UL-580
- ▶ UL-1897
- ▶ TAS-125

## FLORIDA BUILDING PRODUCT APPROVALS

Contact the Acworth, Georgia facility for PAC-150 product approvals.

\*widths are nominal