

PAC T-250 PANEL

MATERIALS

.032 aluminum* 24 gauge steel*
 .040 aluminum* 22 gauge steel*

SPECS

16" or 18" O.C.** 2-5/8" nominal
 from deck

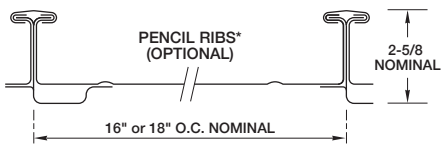
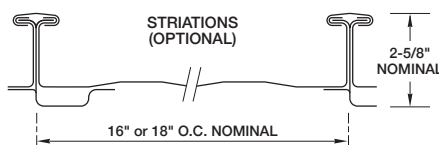
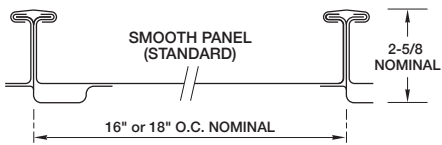
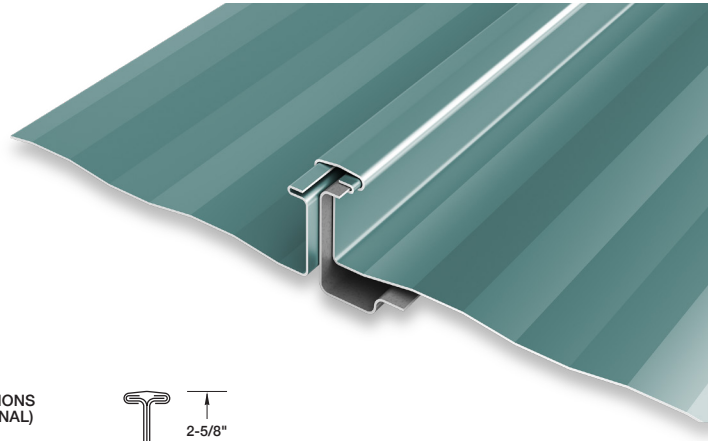

* Offered only in Illinois facility

PRODUCT FEATURES

- ▶ Smooth is standard
- ▶ Maximum factory-produced panel length is 54 ft. (check w/factory for longer lengths)
- ▶ Can be tapered and radiused; consult factory for limitations
- ▶ Architectural/structural panel
- ▶ Factory-applied sealant in seam cover
- ▶ 35-year non-prorated finish warranty

- ▶ Field forming panels are available for long length requirements
- ▶ Weathertightness warranty available
- ▶ Continuous and/or intermittent clips
- ▶ Consult factory*

MATERIAL

- ▶ 24 gauge steel
- ▶ 22 gauge steel
- ▶ .032 aluminum
- ▶ .040 aluminum

- ▶ Galvalume Plus available

TESTING

- ▶ T-250 Panel ASTM 283 & 331
- ▶ T-250 Panel ASTM 1680 & 1646
- ▶ T-250 Panel ASTM E1592
- ▶ T-250 Panel ASTM E2140
- ▶ T-250 Panel FM 4474
- ▶ UL 580
- ▶ UL 1897

* Not available in all locations. Consult PAC rep for availability.

** widths are nominal